

---

CENTRAL  
FLORIDA  
EXPRESSWAY  
AUTHORITY

---

*LIGHTING DESIGN DETAILS*

*FOR DESIGN, CONSTRUCTION, MAINTENANCE AND UTILITY  
OPERATIONS ON THE CFX SYSTEM*

*MARCH 2025*

CENTRAL FLORIDA EXPRESSWAY AUTHORITY  
4974 ORL TOWER RD.  
ORLANDO, FL 32807  
PHONE NUMBER: (407) 690-5000  
FAX NUMBER: (407) 690-5011

W:\50088189\CFX Design Guidelines\CADD and Details\Lighting\Lighting - Progress Working Files\2 - Index of Sheets\LT\_INDEX.DGN  
 3/7/2025 3:04:22 PM ggrant@ham

SHEET NO.	TITLE	FILE NAME (.DGN)
ii	COVER INDEX OF SHEETS	LT_COVER LT_INDEX
<b>TYPICAL DETAILS</b>		
A-1	GENERAL AND PAY ITEM NOTES	LT_A01
A-2	GENERAL AND PAY ITEM NOTES	LT_A01
A-3	GENERAL AND PAY ITEM NOTES	LT_A01
A-4	MAINTENANCE PAY ITEMS & QUANTITY PERCENTAGES	LT_A04
A-5	TEMPORARY LIGHTING NOTES AND DETAILS	LT_A05
A-6	LEGEND	LT_A06
A-7	POLE DATA	LT_A07
A-8	UNDERDECK LUMINAIRE DATA	LT_A08
A-9	SIGN LUMINAIRE DATA	LT_A09
A-10	LOAD CENTER DATA	LT_A10
<b>CONDUIT DETAILS</b>		
B-1	CONDUIT INSTALLATION DETAILS	LT_B01
B-2	CONDUIT INSTALLATION DETAILS	LT_B02
B-3	CONDUIT INSTALLATION DETAILS - TYPICAL DIRECTIONAL BORE	LT_B03
B-4	CONDUIT INSTALLATION DETAILS	LT_B04
<b>PULL AND SPLICE BOX DETAILS</b>		
C-1	PULL BOXES AND CONCRETE APRON DETAIL	LT_C01
<b>POLE CABLE DISTRIBUTION SYSTEM DETAILS</b>		
D-1	GROUND MOUNT POLE CABLE DISTRIBUTION SYSTEM	LT_D01
D-2	WALL MOUNT POLE CABLE DISTRIBUTION SYSTEM	LT_D02
D-3	WALL MOUNT DOUBLE POLE CABLE DISTRIBUTION SYSTEM	LT_D03
<b>LED SIGN LIGHTING DETAILS</b>		
E-1	LED SIGN LIGHTING DETAILS	LT_E01
E-2	LED SIGN LIGHTING DETAILS	LT_E02
E-3	SIGN LIGHTING TILT ANGLE DETAIL	LT_E03
<b>UNDERDECK LIGHTING MOUNTING DETAILS</b>		
F-1	UNDERDECK LIGHTING MOUNTING DETAILS	LT_F01
F-2	UNDERDECK LIGHTING MOUNTING DETAILS	LT_F02
F-3	UNDERDECK & SIGN LIGHTING MOUNTING DETAILS	LT_F03
F-4	BRIDGE MOUNTED SIGN LIGHTING MOUNTING DETAILS	LT_F04
F-5	REDUNDANT LUMINAIRE SUPPORT DETAIL	LT_F05
<b>REMOTE LED DRIVER CABINET DETAILS</b>		
G-1	SMALL SIZE REMOTE LED DRIVER CABINET DETAILS	LT_G01
G-2	MEDIUM SIZE REMOTE LED DRIVER CABINET DETAILS	LT_G02
G-3	LARGE SIZE REMOTE LED DRIVER CABINET DETAILS	LT_G03
<b>REMOTE DRIVER CABINET CONDUIT ROUTING DETAILS</b>		
H-1	REMOTE LED DRIVER CABINET DETAILS	LT_H01
<b>MAINTENANCE LIGHTING DETAILS</b>		
J-1	MAINTENANCE LIGHTING FOR BOX GIRDERS	LT_J01
J-2	MAINTENANCE LIGHTING FOR BOX GIRDERS	LT_J02
<b>SERVICE POINT DETAILS</b>		
K-1	ELECTRIC SERVICE ASSEMBLY WITHOUT A TRANSFORMER	LT_K01
K-2	ELECTRICAL SERVICE ASSEMBLY WIRING DIAGRAM WITHOUT A TRANSFORMER	LT_K02
K-3	ELECTRIC SERVICE ASSEMBLY WITH A TRANSFORMER	LT_K03
K-4	ELECTRICAL SERVICE ASSEMBLY WIRING DIAGRAM WITH A TRANSFORMER	LT_K04
K-5	SERVICE POINT DETAILS	LT_K05
K-6	LIGHTING CABINET DETAILS	LT_K06
K-7	PANELBOARD SCHEDULES	LT_K07
<b>ARC FLASH WARNING LABEL AND NOTES</b>		
L-1	ARC FLASH WARNING LABEL AND NOTES	LT_L01

REVISIONS				ENGINEER OF RECORD FULL NAME, P.E. P.E. LICENSE NUMBER 99999 ENGINEER OF RECORD COMPANY NAME ENGINEER OF RECORD COMPANY STREET ENGINEER OF RECORD CITY, STATE AND ZIP	PROJECT NAME (1 to 3 LINES)			INDEX OF SHEETS	SHEET NO.
DATE	DESCRIPTION	DATE	DESCRIPTION		ROAD NO.	PROJECT NO.			ii

THE OFFICIAL RECORD OF THIS SHEET IS THE ELECTRONIC FILE DIGITALLY SIGNED AND SEALED UNDER RULE 61G15-23.004, F.A.C.



**UTILITY NOTES:**

1. AS REQUIRED PER FLORIDA STATUTE 556, CALL SUNSHINE STATE ONE-CALL OF FLORIDA, INC., AT 1-800-432-4770, NO LESS THAN 2 OR MORE THAN 5 BUSINESS DAYS BEFORE BEGINNING ANY EXCAVATION OR DEMOLITION. NOT ALL UTILITY AGENCIES/OWNERS ARE MEMBERS OF SUNSHINE STATE ONE-CALL OF FLORIDA, INC. A CONTACT LIST OF CFX OWNED FACILITIES:
  - A. CFX (FIBER): WILLIAM (PAT) COLLINS - (407) 690-5000 EXT: 5056  
OR CFX (FIBER/ITS) BRENT POOLE - (407) 690-5000 EXT: 5338
  - B. CFX ROADWAY MAINTENANCE (SR429, SR414, SR451, SR453):  
VERSAR - (689) 252-0556
  - C. CFX ROADWAY MAINTENANCE (SR408, SR417, SR528): JCS - (407) 249-9122
  - D. CFX LANDSCAPING: BEN BAKER (GEC) - (407) 484-2699
  - E. CFX FACILITIES MAINTENANCE: VERSAR - (855) 932-5790
  - F. CFX TOLLING MAINTENANCE: TRANSORE (407) 382-1301
2. STAKE ALL POLE LOCATIONS AND REQUEST UTILITY COMPANIES TO LOCATE AND MARK UNDERGROUND UTILITIES PRIOR TO EXCAVATING.
3. THE CONTRACTOR IS RESPONSIBLE FOR VERIFYING UNDERGROUND UTILITIES VERTICALLY AND HORIZONTALLY (VVH) FOR ALL CONDUIT INSTALLATIONS. THE COST FOR THE VVHS SHALL BE INCLUDED IN THE COST OF THE CONDUIT.
4. THE CONTRACTOR IS RESPONSIBLE FOR VERIFYING LOCATIONS OF EXISTING ROADWAY LIGHTING AND FIBER OPTIC CONDUITS AS WELL AS OTHER UTILITIES PRIOR TO INSTALLATION OF POLE FOUNDATIONS, LOAD CENTERS, SIGN STRUCTURES, CONDUITS AND PULL BOXES.
5. MAKE SURE THAT ALL NECESSARY PROTECTIVE MEASURES ARE TAKEN TO SAFEGUARD EXISTING UTILITIES DURING LIGHTING EQUIPMENT INSTALLATIONS.
6. THE CONTRACTOR SHALL EXERCISE ALL APPROPRIATE SAFETY MEASURES WHEN WORKING IN OR AROUND AREAS OF OVERHEAD ELECTRICAL/TRANSMISSION LINES OR UNDERGROUND UTILITIES IN ACCORDANCE WITH THE LATEST VERSION OF THE OSHA REQUIREMENTS. HAND DIGGING SHALL OCCUR ALL AROUND UTILITIES.
7. POWER SUPPLY LOCATIONS HAVE BEEN COORDINATED WITH DUKE ENERGY AND THE ORLANDO UTILITIES COMMISSION. CONTACT EACH RESPECTIVE POWER COMPANY IMMEDIATELY FOLLOWING THE PRE-CONSTRUCTION MEETING TO ENSURE THAT ALL ELECTRIC EQUIPMENT CAN BE AT LOCATIONS INDICATED WITHIN THESE PROJECT PLANS.
  - A. DUKE ENERGY CONTACT: (800) 700-8744
  - B. ORLANDO UTILITIES COMMISSION CONTACT: (407) 423-9018
8. ESTABLISH, STAKE, PAINT AND MAINTAIN LIGHT POLE LOCATIONS WITH THE USE OF A FLORIDA REGISTERED LAND SURVEYOR. THE LIGHT POLE LOCATIONS ARE TO BE RE-ESTABLISHED BY A FLORIDA REGISTERED LAND SURVEYOR IF, DURING THE CONSTRUCTION PROCESS, THE STAKES AND/OR PAINTED MARKS ARE NO LONGER PRESENT. NO ADDITIONAL PAYMENT WILL BE PERMITTED.
9. THE LOCATION OF EXISTING UTILITIES, AS SHOWN ON THESE PLANS, ARE APPROXIMATE AND BASED ON THE INFORMATION FURNISHED TO THE ENGINEER BY THE UTILITY OWNER(S) AND ARE SHOWN AS NOTICE THAT UNDERGROUND UTILITIES EXIST.
10. THE LOCATION OF THE CONDUCTORS, CONDUITS, JUNCTION BOXES, SERVICE POINTS, AND OTHER LIGHTING RELATED EQUIPMENT ARE DIAGRAMMATIC ONLY AND MAY BE SHIFTED BY THE EOR AND CEI ENGINEER TO ACCOMMODATE LOCAL CONDITIONS AND EXISTING UTILITY LOCATIONS. CONDUIT SHALL BE PLACED WITHIN EXISTING RIGHT-OF-WAY.
11. HAND DIG THE FIRST 4' OF ALL UTILITY CROSSINGS TO VERIFY AND MINIMIZE POSSIBLE UTILITY CONFLICTS.
12. ACQUIRE ALL PERMITS BY OTHER AGENCIES FOR INSTALLATION OF INFRASTRUCTURE NOT ON CFX FACILITIES. NO ADDITIONAL COMPENSATION WILL BE PERMITTED.
13. MAINTAIN THE EXISTING FIBER OPTIC NETWORK (FON) WITHIN THE LIMITS OF CONSTRUCTION. AT NO TIME SHALL THERE BE ANY LOSS OF COMMUNICATIONS OR DATA ALONG THE CFX FIBER OPTIC NETWORK. ANY CONSTRUCTION ACTIVITIES WITHIN TEN FEET OF THE FIBER OPTIC NETWORK SHALL BE PERFORMED ON ONE SIDE OF THE ROAD AT A TIME. REVIEW CFX ITS SPECIFICATIONS 603A & 631 FOR OTHER FON PRESERVATION DETAILS.
14. LOCATE AND PROTECT EXISTING CFX FIBER OPTIC CABLES AND BURIED ELECTRICAL LINES DURING THE INSTALLATION OF NEW CONDUIT AND PULL BOXES.
15. ADHERE TO ALL APPLICABLE PROVISIONS OF EXISTING UTILITY EASEMENTS.

**ELECTRICAL EQUIPMENT NOTES:**

1. CONNECTIONS TO EXISTING POWER METERS TO BE ACCOMPLISHED PER STATE AND LOCAL CODES. EACH POWER SERVICE METER ENCLOSURE SHALL BE CORRECTLY IDENTIFIED ON THE OUTSIDE FRONT BY A NON-FERROUS METAL OR PLASTIC PLATE PER DUKE ENERGY OR OUC STANDARDS. THE PLATE SHALL BE RIVETED TO THE METER ENCLOSURE. A LICENSED ELECTRICIAN IS TO PRE-EXAMINE EACH SITE TO DETERMINE THE FEASIBILITY OF CONNECTING TO THE PROPOSED POWER SOURCE. CONNECTIONS MUST BE MADE THROUGH AN EXISTING OR NEW BREAKER PANEL WITH THE APPROPRIATE CIRCUIT BREAKER AND CORRECT WIRE GAUGE. ALL MATERIALS, EQUIPMENT AND LABOR TO BE SUPPLIED FOR A COMPLETE CONNECTION AND IS TO BE PAID UNDER PAY ITEM 639-1-111 AND 639-1-112.
2. INSTALL PROPERLY GROUNDED SURGE PROTECTION DEVICES TYPE I AT ALL SERVICE-ENTRANCE RATED FUSED DISCONNECT SWITCHES. INSTALL PROPERLY GROUNDED SURGE PROTECTION DEVICES TYPE II WITH LEAD LENGTHS NOT TO EXCEED TWELVE (12) INCHES FED VIA TWO-POLE BRANCH CIRCUIT BREAKER LOCATED WITHIN THE PANEL BOARD MOUNTED CLOSEST TO THE SERVICE ENTRANCE POINT. THE LIGHT POLES SHALL BE GROUNDED PER THE CFX LIGHTING STANDARDS REGARDLESS OF LOCAL PRACTICES. GROUNDING THE POLES THROUGH THE HANDHOLE IS UNACCEPTABLE. MANUFACTURER SUPPLIED GROUND TERMINAL SHALL BE USED.
3. IN ACCORDANCE WITH N.E.C. IDENTIFY ALL CIRCUITS AND EQUIPMENT WITH "LAMACOID TAGS".
4. FOR DC CIRCUIT CONDUCTORS PROVIDING POWER TO EQUIPMENT OPERATING AT LESS THAN 60 VDC, EACH CONDUCTOR SHALL ADHERE TO THE SAME NEC REQUIRMENTS FOR CONDUCTOR IDENTIFICATION AS DC CIRCUITS OPERATING AT GREATER THAN 60 VDC.
5. ALL EXTERNALLY CONNECTED EQUIPMENT (SURGE PROTECTION DEVICES, PHOTOCELLS, ETC.) AT SERVICE ENTRANCE LOCATIONS, LIGHTING LOAD CENTERS AND CABINETS SHALL BE SILICONE SEALED, BOTH INSIDE AND OUTSIDE, AT THE EQUIPMENT'S MOUNTING POINTS POST-INSTALLATION.
6. PROVIDE TYPE-WRITTEN DIRECTORIES WITH THE SAME POLE IDENTIFICATION TAG NUMBERING SYSTEM AS INSTALLED IN THE FIELD FOR EACH POLE.
7. ALL SPARE BREAKERS SHALL BE PLACED IN THE 'OFF' POSITION.
8. ELECTRICAL SPLICES ARE NOT PERMITTED WITHIN SERVICE ENTRANCE EQUIPMENT, LOAD CENTERS, LIGHTING CABINETS. ALL ELECTRICAL WIRING SHALL BE CONNECTED TO A DESIGNATED TERMINAL LUG.
9. PROVIDE SEPARATE COPPER BUSBARS FOR NEUTRAL AND GROUND CONNECTIONS. NEUTRAL BUSBARS SHALL BE INSTALLED WITH AN ISOLATOR FROM THE PANEL. GROUND BUSBARS SHALL BE CONNECTED TO THE CHASSIS OF THE PANEL.
10. MULTI-POLE BREAKERS SHALL HAVE A SINGLE HANDLE ON THE CENTER. TWO SINGLE POLE BREAKERS TIED TOGETHER IS NOT PERMITTED.
11. ONLY ONE WIRE SHALL LAND WITHIN EACH TERMINAL LUG. DOUBLE-TAPPING WILL NOT BE PERMITTED UNLESS THE LUG IS RATED AND IS SO LISTED (NEC 110.14).
12. ALL ELECTRICAL EQUIPMENT SHALL BE NEMA RATED FOR THE APPLICATION. PENETRATIONS PERFORMED, WHERE WATER MAY ENTER, SHALL BE SEALED BOTH INSIDE AND OUT WITH CORRECTLY SIZED HARDWARE. PLACE SILICONE SEALANT AROUND THE INSIDE AND OUTSIDE EDGES ANY ELECTRICAL EQUIPMENT WHERE IT COMES INTO CONTACT WITH CONCRETE PEDESTALS.
13. ALL ELECTRICAL TERMINATION POINTS SHALL BE SECURED AND TORQUED TO MANUFACTURER'S SPECIFICATIONS.

W:\50088189\CFX Design Guidelines\CADD and Details\Lighting\Lighting - Progress Working Files\A1 - A3 - General Notes\UT\_A01.dgn 3:04:22 PM 3/7/2025 ggrant@ham

REVISIONS				ENGINEER OF RECORD FULL NAME, P.E. P.E. LICENSE NUMBER 99999 ENGINEER OF RECORD COMPANY NAME ENGINEER OF RECORD COMPANY STREET ENGINEER OF RECORD CITY, STATE AND ZIP	PROJECT NAME (1 to 3 LINES)			GENERAL AND PAY ITEM NOTES	SHEET NO.
DATE	DESCRIPTION	DATE	DESCRIPTION		ROAD NO.	PROJECT NO.			A-2

THE OFFICIAL RECORD OF THIS SHEET IS THE ELECTRONIC FILE DIGITALLY SIGNED AND SEALED UNDER RULE 61G15-23.004, F.A.C.





















**GENERAL NOTES:**

1. INSTALL CONDUIT IN ACCORDANCE WITH FDOT STANDARD SPECIFICATIONS, SECTION 630, OR AS AMENDED BY CFX. IN CASES OF DISCREPANCY, THE REQUIREMENTS SPECIFIED HEREIN SHALL SUPERCEDE.
2. WHEN INSTALLING CONDUIT UNDER SIDEWALK BY OPEN TRENCH, REPLACE THE ENTIRE SIDEWALK SLAB.

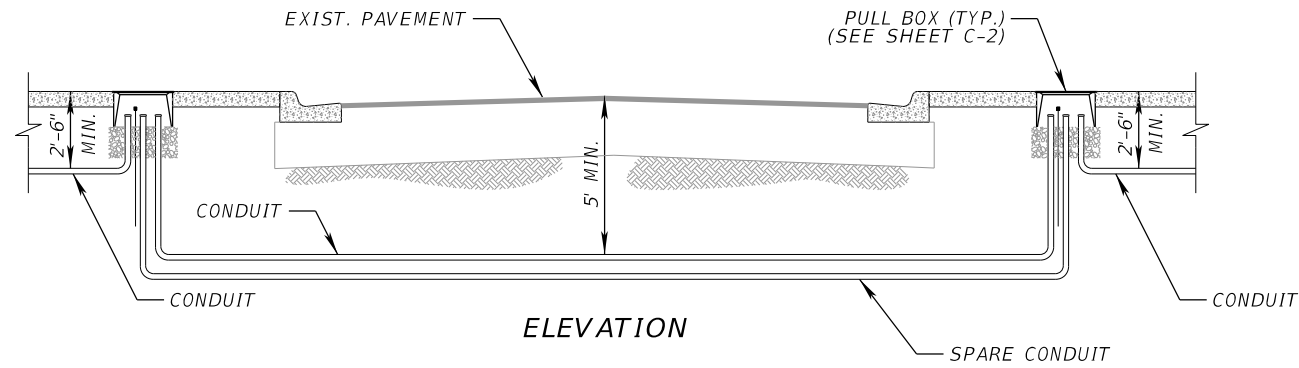

CURB AND GUTTER

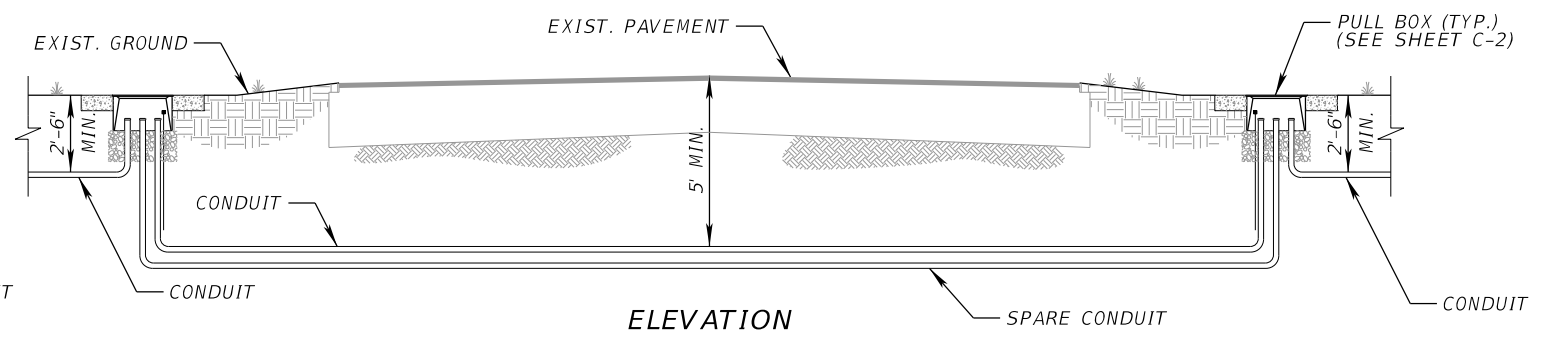

FLUSH SHOULDER

NOT TO SCALE

3/7/2025 3:04:25 PM W:\50088189\CFX Design Guidelines\CADD and Details\Lighting -Progress Working Files\B - Conduit Details\LT\_B01.dgn ggrant\ham

REVISIONS				ENGINEER OF RECORD FULL NAME, P.E. P.E. LICENSE NUMBER 99999 ENGINEER OF RECORD COMPANY NAME ENGINEER OF RECORD COMPANY STREET ENGINEER OF RECORD CITY, STATE AND ZIP	PROJECT NAME (1 to 3 LINES)			CONDUIT INSTALLATION DETAILS	SHEET NO.
DATE	DESCRIPTION	DATE	DESCRIPTION		ROAD NO.	PROJECT NO.			B-1

THE OFFICIAL RECORD OF THIS SHEET IS THE ELECTRONIC FILE DIGITALLY SIGNED AND SEALED UNDER RULE 61G15-23.004, F.A.C.

W:\50088189\CFX Design Guidelines\CADD and Details\Lighting -Progress Working Files\B - Conduit Details\LT\_B02.dgn  
 3:04:26 PM  
 3/7/2025  
 ggrant@ham

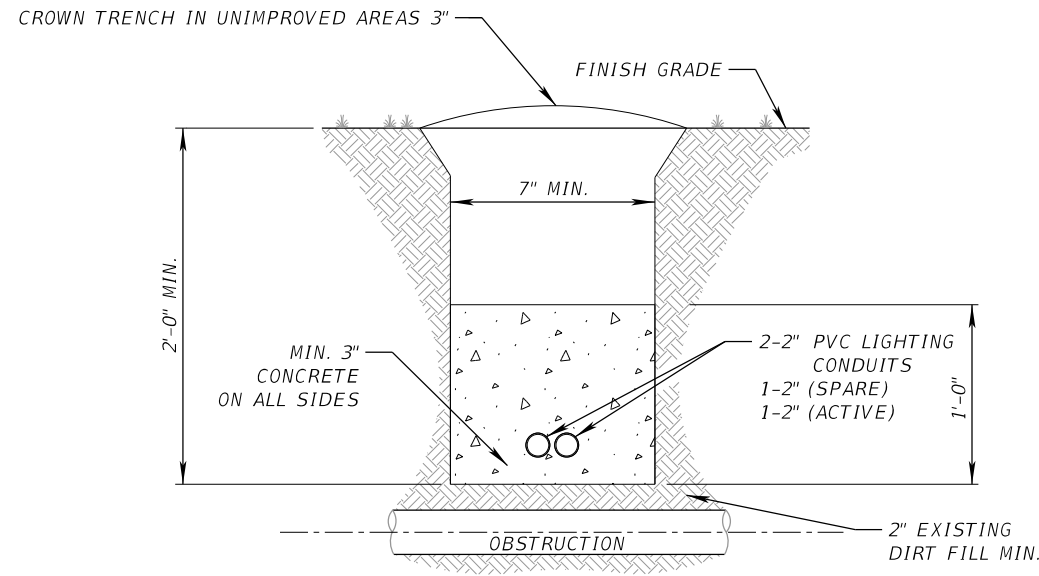

**DETAIL A**

TYPICAL CROSSING WHERE OBSTRUCTION IS LESS THAN 30" IN DEPTH

**NOTES:**

1. A MINIMUM OF 2'-0" SHALL BE MAINTAINED FROM EXISTING LANDSCAPE FEATURES. LANDSCAPE REPLACEMENT SHALL BE IN KIND AND SUBJECT TO THE APPROVAL OF CFX.
2. REPLACEMENT OF FILL, BASE, SURFACE (ASPHALT), CURB AND DRAINAGE STRUCTURES WILL BE IN ACCORDANCE WITH APPLICABLE COUNTY AND CITY UTILITY ACCOMODATION MANUAL.
3. CONSTRUCTION CORRIDOR SHALL BE RESTORED TO ORIGINAL OR IMPROVED CONDITION AND VERIFIED BY CFX OR THEIR DESIGNEE.
4. ALL TRENCH WIDTHS SHALL BE WIDE ENOUGH TO ACCOMODATE MECHANICAL COMPACTION EQUIPMENT FOR PROPER COMPACTION IN ACCORDANCE WITH FDOT STANDARD SPECIFICATIONS.
5. ALL TRENCHES SHALL BE BACKFILLED & COMPACTED BY THE END OF EACH WORK DAY.
6. CFX APPROVED JOINT COUPLINGS SHALL BE USED.
7. CONDUIT PATH WILL BE ROUTED TO AVOID ANY OBSTRUCTIONS SHOULD OBSTRUCTIONS BE ENCOUNTERED, THE FOLLOWING HIERARCHY WILL BE STRICTLY ADHERED TO:
  - A. ROUTE CONDUIT AROUND OBSTRUCTION USING SWEEPING BENDS WITH A MINIMUM HORIZONTAL CLEARANCE OF 12". IF THIS CANNOT BE ACCOMPLISHED, CONDUIT ROUTING WILL BE MADE UNDER THE OBSTRUCTION WITH A MINIMUM VERTICAL CLEARANCE OF 12".
  - B. IF THE ABOVE CANNOT BE ACCOMPLISHED, THEN DETAIL A ON THIS SHEET WILL BE ALLOWED. PRIOR TO COMMENCING DETAIL A, OWNERS APPROVAL MUST BE OBTAINED. THE METHODS IN NOTE 7.A. ARE THE PREFERRED METHODS.

NOT TO SCALE

REVISIONS				ENGINEER OF RECORD FULL NAME, P.E. P.E. LICENSE NUMBER 99999 ENGINEER OF RECORD COMPANY NAME ENGINEER OF RECORD COMPANY STREET ENGINEER OF RECORD CITY, STATE AND ZIP	PROJECT NAME (1 to 3 LINES)			CONDUIT INSTALLATION DETAILS	SHEET NO.
DATE	DESCRIPTION	DATE	DESCRIPTION		ROAD NO.	PROJECT NO.			B-2

THE OFFICIAL RECORD OF THIS SHEET IS THE ELECTRONIC FILE DIGITALLY SIGNED AND SEALED UNDER RULE 61G15-23.004, F.A.C.

W:\50088189\CFX Design Guidelines\CADD and Details\Lighting -Progress Working Files\B - Conduit Details\LT\_B03.dgn  
 3:04:26 PM  
 3/7/2025  
 ggrant@ham

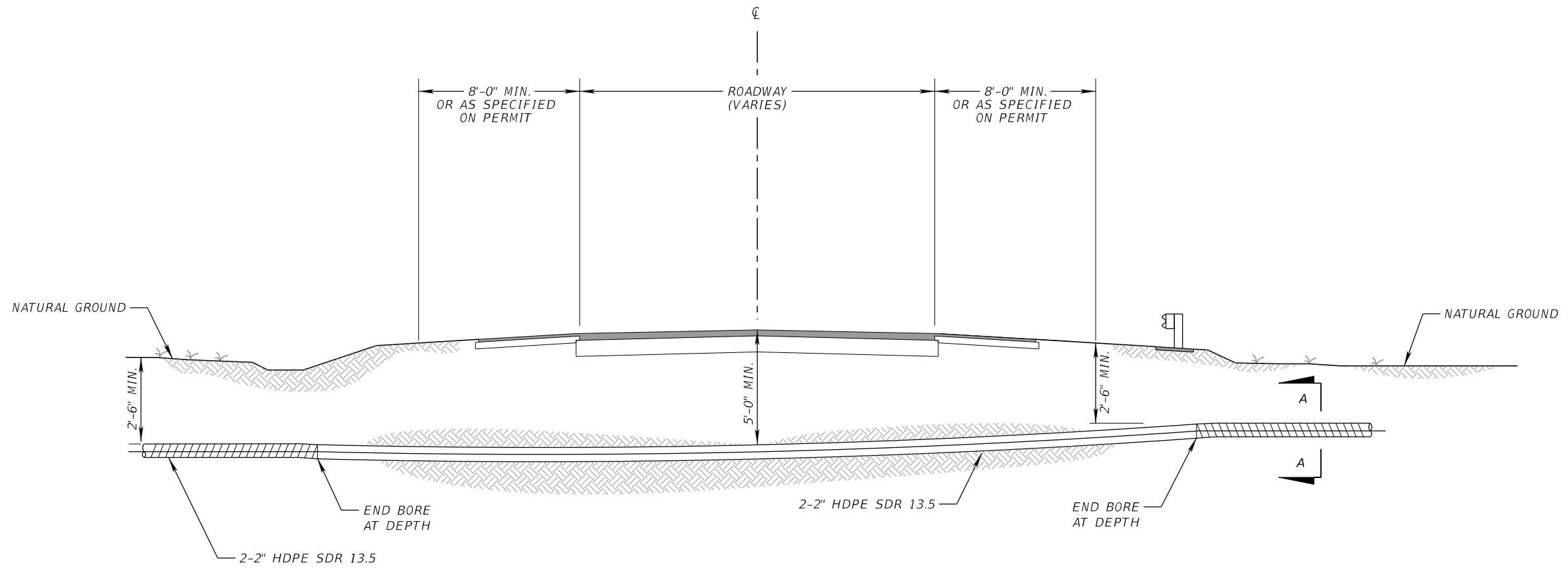

**TYPICAL DIRECTIONAL BORE**

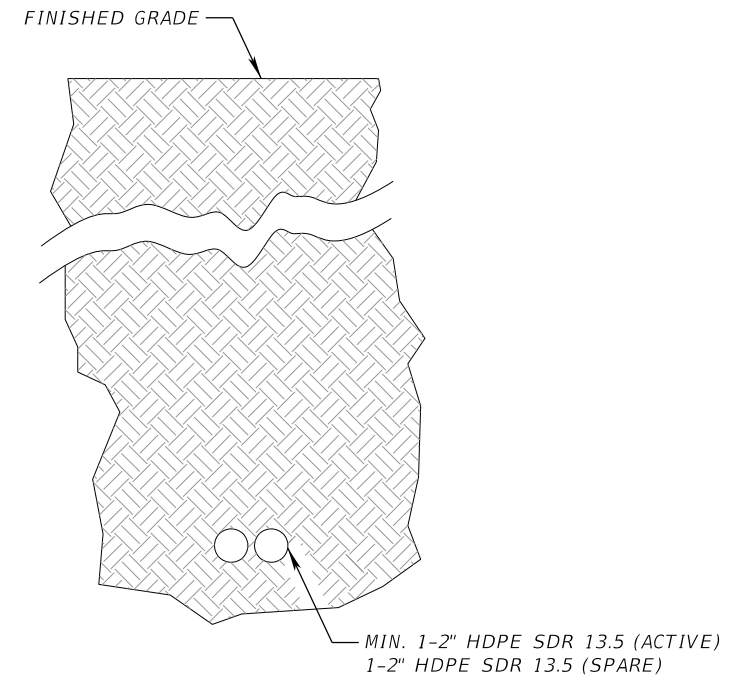

**SECTION A-A**

**NOTE:**

- UTILITY IN THE PATH OF THE BORE SHALL BE LOCATED AND THE DEPTH OF THE BORE CROSSING SHALL BE DELINEATED TO CROSS UNDER OR OVER UTILITY WITH 12" MINIMUM SEPARATION.

NOT TO SCALE

REVISIONS				ENGINEER OF RECORD FULL NAME, P.E. P.E. LICENSE NUMBER 99999 ENGINEER OF RECORD COMPANY NAME ENGINEER OF RECORD COMPANY STREET ENGINEER OF RECORD CITY, STATE AND ZIP	PROJECT NAME (1 to 3 LINES)		<b>CENTRAL FLORIDA EXPRESSWAY AUTHORITY</b>	<b>CONDUIT INSTALLATION DETAILS</b> <i>TYPICAL DIRECTIONAL BORE</i>	SHEET NO.
DATE	DESCRIPTION	DATE	DESCRIPTION		ROAD NO.	PROJECT NO.			B-3

THE OFFICIAL RECORD OF THIS SHEET IS THE ELECTRONIC FILE DIGITALLY SIGNED AND SEALED UNDER RULE 61G15-23.004, F.A.C.

W:\50088189\CFX Design Guidelines\CADD and Details\Lighting - Progress Working Files\B - Conduit Details\LT\_B04.dgn  
 3:04:27 PM  
 3/7/2025  
 ggrant@ham

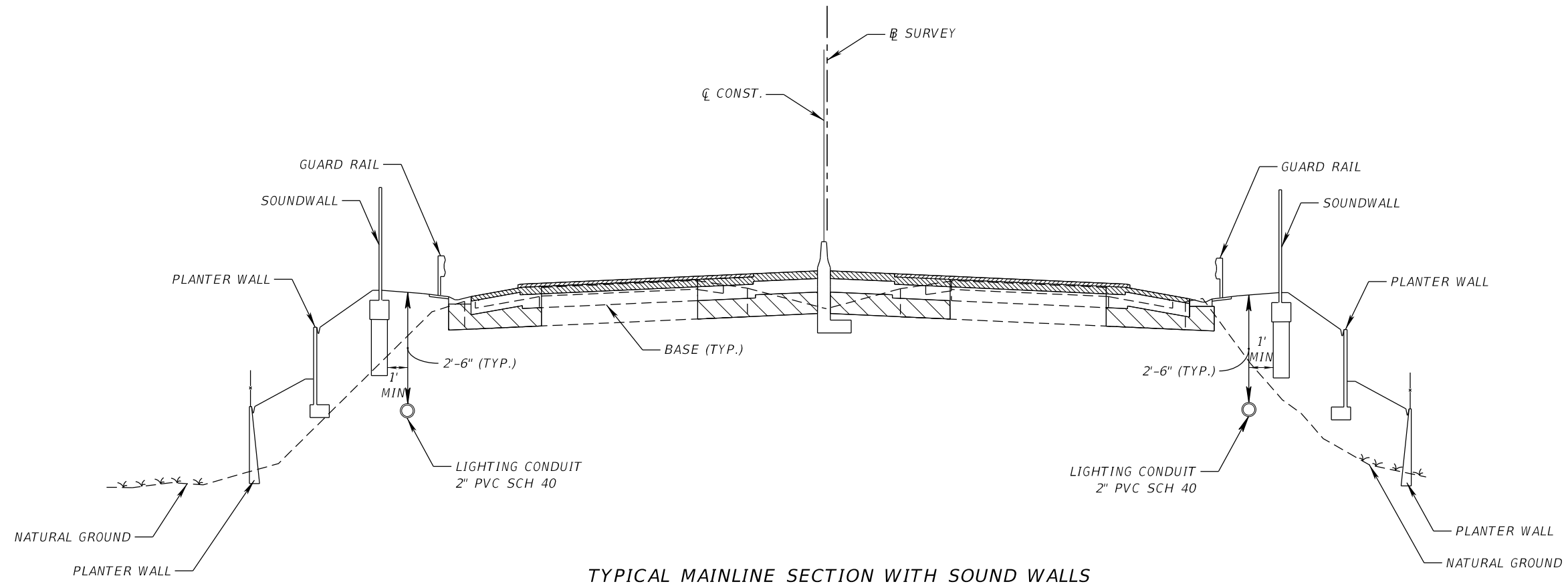

TYPICAL MAINLINE SECTION WITH SOUND WALLS

NOT TO SCALE

REVISIONS				ENGINEER OF RECORD FULL NAME, P.E. P.E. LICENSE NUMBER 99999 ENGINEER OF RECORD COMPANY NAME ENGINEER OF RECORD COMPANY STREET ENGINEER OF RECORD CITY, STATE AND ZIP	PROJECT NAME (1 to 3 LINES)		<b>CENTRAL FLORIDA EXPRESSWAY AUTHORITY</b>	CONDUIT INSTALLATION DETAILS	SHEET NO.
DATE	DESCRIPTION	DATE	DESCRIPTION		ROAD NO.	PROJECT NO.			B-4

THE OFFICIAL RECORD OF THIS SHEET IS THE ELECTRONIC FILE DIGITALLY SIGNED AND SEALED UNDER RULE 61G15-23.004, F.A.C.

W:\50088189\CFX Design Guidelines\CADD and Details\Lighting\Lighting - Pull And Splice Boxes\LI\_C01.dgn  
 3:04:28 PM  
 3/7/2025  
 ggrant@ham

**NOTES:**

1. OUTSIDE EDGE OF CONCRETE APRON SHALL BE CAST AGAINST FORMWORK.
2. CONCRETE APRON TO BE PLACED AROUND ALL POLES, UPRIGHTS AND PULL BOXES. IN URBAN AREAS OR WHERE SPACE IS LIMITED, DIMENSIONS MAY BE ADJUSTED AS SHOWN IN THE PLANS OR APPROVED BY THE CEI ENGINEER.
3. INSTALL A 1'-0" WIDE (MIN.) CONCRETE APRON AROUND ALL PULL BOXES USING CLASS NS CONCRETE. SLOPE THE APRON AWAY FROM THE PULL BOX.
4. WHERE MULTIPLE PULL BOXES ARE PLACED SIDE BY SIDE, MAINTAIN AT LEAST 3" BETWEEN THE PULL BOXES.
5. COORDINATE CONSTRUCTION OF CONCRETE APRON WITH PROPOSED FINAL GRADE. GRADE AND COMPACT SIDE SLOPES AROUND THE CONCRETE APRON TO PROVIDE A STABLE AND LEVEL WORKING AREA AND TIE INTO THE PROPOSED EMBANKMENT.

DIRECTION OF TRAVEL

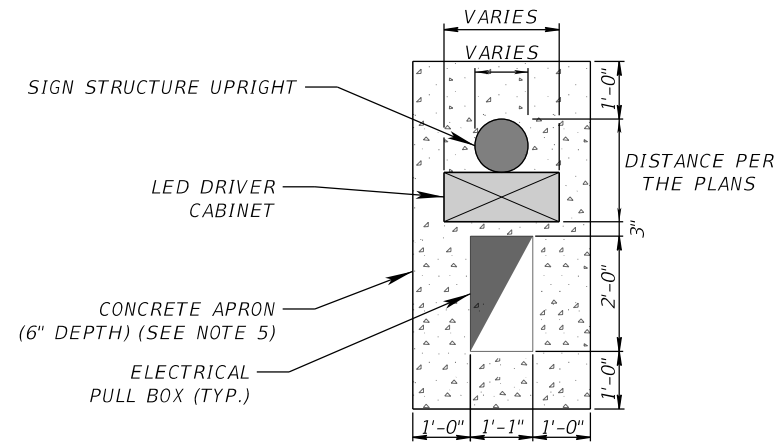

OVERHEAD SIGN LIGHTING DETAIL

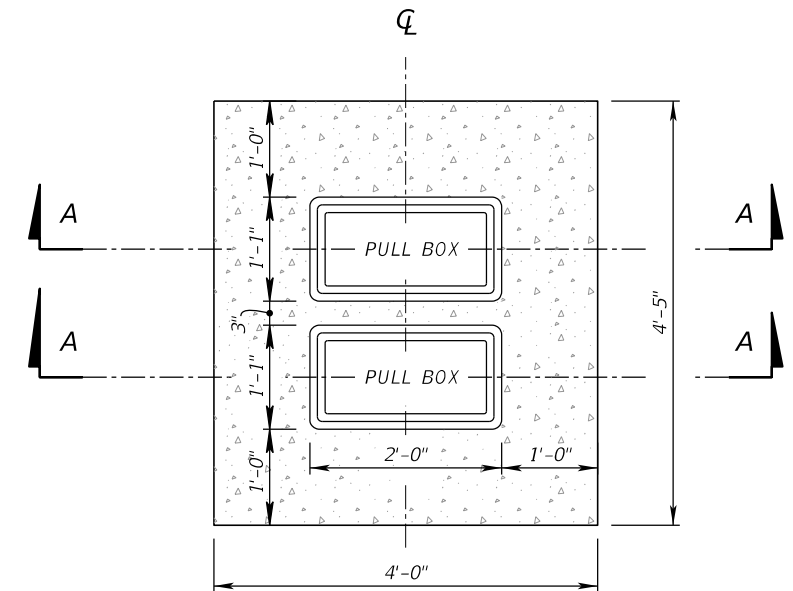

CONCRETE APRON (TYP.)

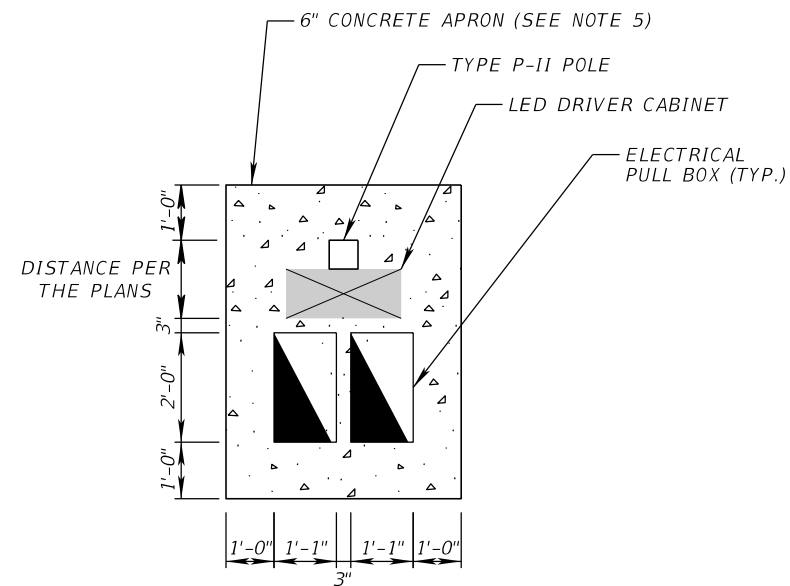

UNDERDECK AND BRIDGE MOUNT

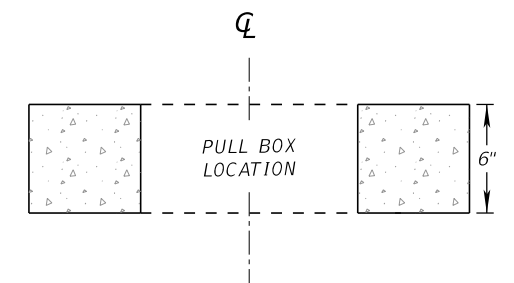

SECTION A-A

NOT TO SCALE

REVISIONS				ENGINEER OF RECORD FULL NAME, P.E. P.E. LICENSE NUMBER 99999 ENGINEER OF RECORD COMPANY NAME ENGINEER OF RECORD COMPANY STREET ENGINEER OF RECORD CITY, STATE AND ZIP	PROJECT NAME (1 to 3 LINES)		<b>CENTRAL FLORIDA EXPRESSWAY AUTHORITY</b>	<i>PULL BOXES AND CONCRETE APRON DETAIL</i>	SHEET NO.
DATE	DESCRIPTION	DATE	DESCRIPTION		ROAD NO.	PROJECT NO.			C-1

THE OFFICIAL RECORD OF THIS SHEET IS THE ELECTRONIC FILE DIGITALLY SIGNED AND SEALED UNDER RULE 61G15-23.004, F.A.C.

W:\50088189\CFX Design Guidelines\CADD and Details\Lighting - Progress Working Files\D - Ground & Wall Mount Pole Cable Distribution System\LT\_001.dgn 3:04:28 PM 3/7/2025 ggrant@ham

**KEYED NOTES:**

- 1 3 - #10 TC-ER 600V XHHW-2 XLPE LUMINAIRE CABLE
- 2 HEAT SHRINK (BLACK, RED & GREEN), AT BOTH ENDS OF ALL FUSE HOLDERS, HEAVY-WALL SEALANT COATED TUBING, UL LISTED
- 3 BREAKAWAY FUSE HOLDER WITH COPPER SLUG (BLACK, RED & GREEN)
- 4 BREAKAWAY FUSE HOLDER (BLACK, RED & GREEN)
- 5 STRAIN RELIEF WITH TIE WRAP
- 6 TIME DELAY FUSE, 10 AMPS, UL LISTED
- 7 SURGE ARRESTOR WITH 3FT XHHW GROUNDING WIRE, ALL MODES OF PROTECTION, UL LISTED
- 8 CADWELD ONE SHOT, FOR PERMANENT EXOTHERMIC CONNECTIONS OF 4 CONDUCTORS TO GROUND ROD
- 9 GELCAP SPLICE KIT, PROTECTING STUB SPLICE UP TO 1000 VOLTS, USED FOR WIDE TEMPERATURE RANGE
- 10 #6 (AWG) BARE SOLID GROUNDING WIRE
- 11 DUCT SEAL WITH UNIVERSAL OXIDE INHIBITOR FOR COPPER TERMINATION
- 12 GROUNDING CHAIR LUG, SUITABLE FOR USE WITH COPPER CONDUCTORS, RATED 600 VOLTS

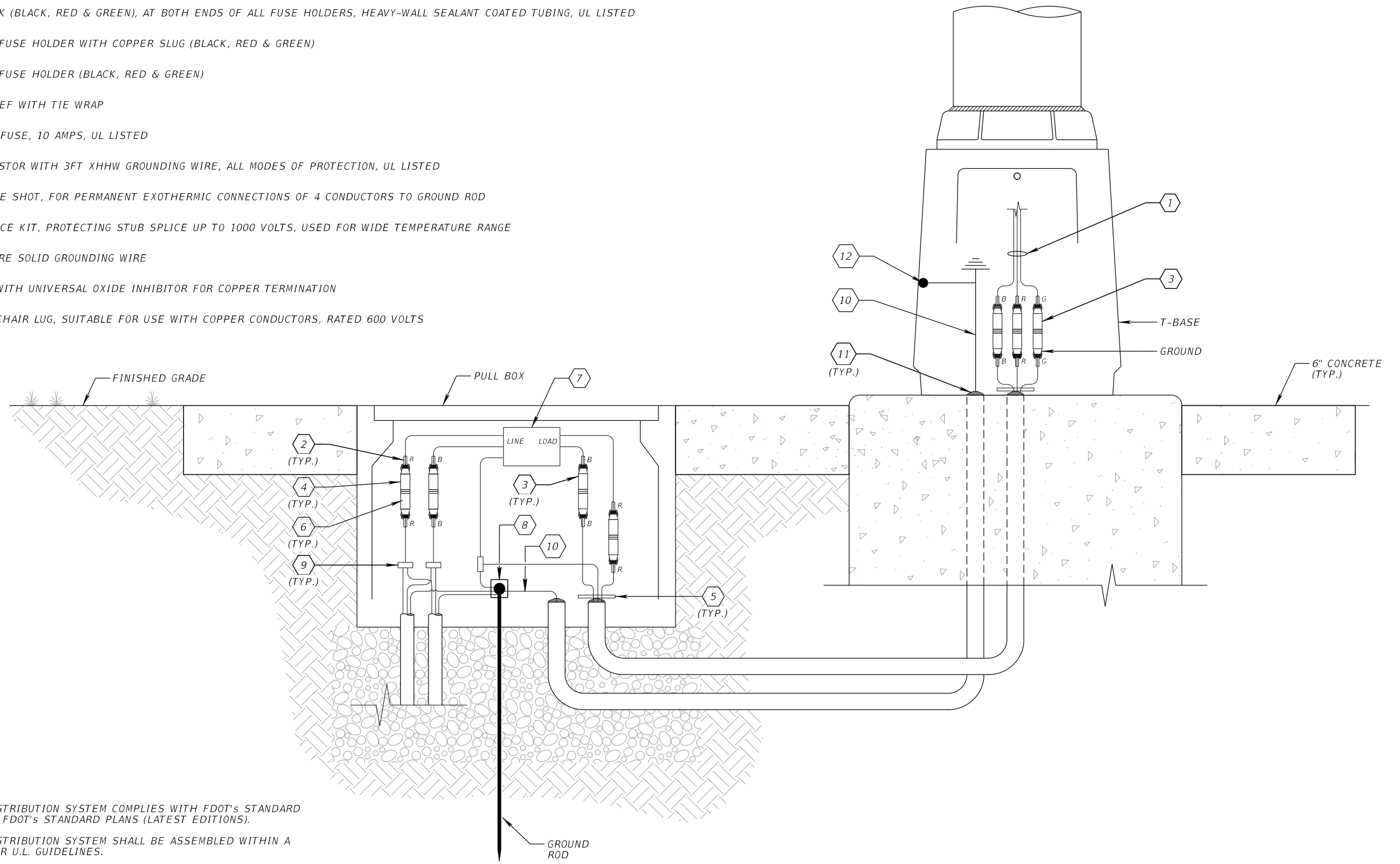

**NOTES:**

- 1. THIS POLE CABLE DISTRIBUTION SYSTEM COMPLIES WITH FDOT'S STANDARD SPECIFICATIONS AND FDOT'S STANDARD PLANS (LATEST EDITIONS).
- 2. THIS POLE CABLE DISTRIBUTION SYSTEM SHALL BE ASSEMBLED WITHIN A U.L. LISTED SHOP, PER U.L. GUIDELINES.

NOT TO SCALE

REVISIONS		ENGINEER OF RECORD FULL NAME, P.E. P.E. LICENSE NUMBER 99999 ENGINEER OF RECORD COMPANY NAME ENGINEER OF RECORD COMPANY STREET ENGINEER OF RECORD CITY, STATE AND ZIP	PROJECT NAME (1 to 3 LINES)		<b>CENTRAL FLORIDA EXPRESSWAY AUTHORITY</b>	<i>GROUND MOUNT POLE CABLE DISTRIBUTION SYSTEM</i>	SHEET NO.
DATE	DESCRIPTION		ROAD NO.	PROJECT NO.			D-1

THE OFFICIAL RECORD OF THIS SHEET IS THE ELECTRONIC FILE DIGITALLY SIGNED AND SEALED UNDER RULE 61G15-23.004, F.A.C.



W:\50088189\CFX Design Guidelines\CADD and Details\Lighting - Progress Working Files\D - Ground & Wall Mount Pole Cable Distribution System\LT\_002.DGN  
 3:04:28 PM  
 3/7/2025  
 grantham

**KEYED NOTES:**

- 1 10-3 TC-ER 600V XHHW-2 XLPE LUMINAIRE CABLE
- 2 HEAT SHRINK (BLACK, RED & GREEN), AT BOTH ENDS OF ALL FUSE HOLDERS, HEAVY-WALL SEALANT COATED TUBING, UL LISTED
- 3 BREAKAWAY FUSE HOLDER WITH COPPER SLUG (BLACK, RED & GREEN)
- 4 BREAKAWAY FUSE HOLDER (BLACK, RED & GREEN)
- 5 TIME DELAY FUSE, 10AMPS, UL LISTED
- 6 SURGE ARRESTOR WITH 3FT XHHW GROUNDING WIRE, ALL MODES OF PROTECTION, UL LISTED
- 7 CADWELD ONE SHOT, FOR PERMANENT EXOTHERMIC CONNECTIONS OF 4 CONDUCTORS TO GROUND ROD
- 8 GELCAP SPLICE KIT, PROTECTING STUB SPLICE UP TO 1000 VOLTS, USED FOR WIDE TEMPERATURE RANGE
- 9 #6 BARE SOLID GROUNDING WIRE
- 10 DUCT SEAL WITH UNIVERSAL OXIDE INHIBITOR FOR COPPER TERMINATION
- 11 GROUNDING CHAIR LUG, SUITABLE FOR USE WITH COPPER CONDUCTORS, RATED 600 VOLTS
- 12 EMBEDDED PULL BOX

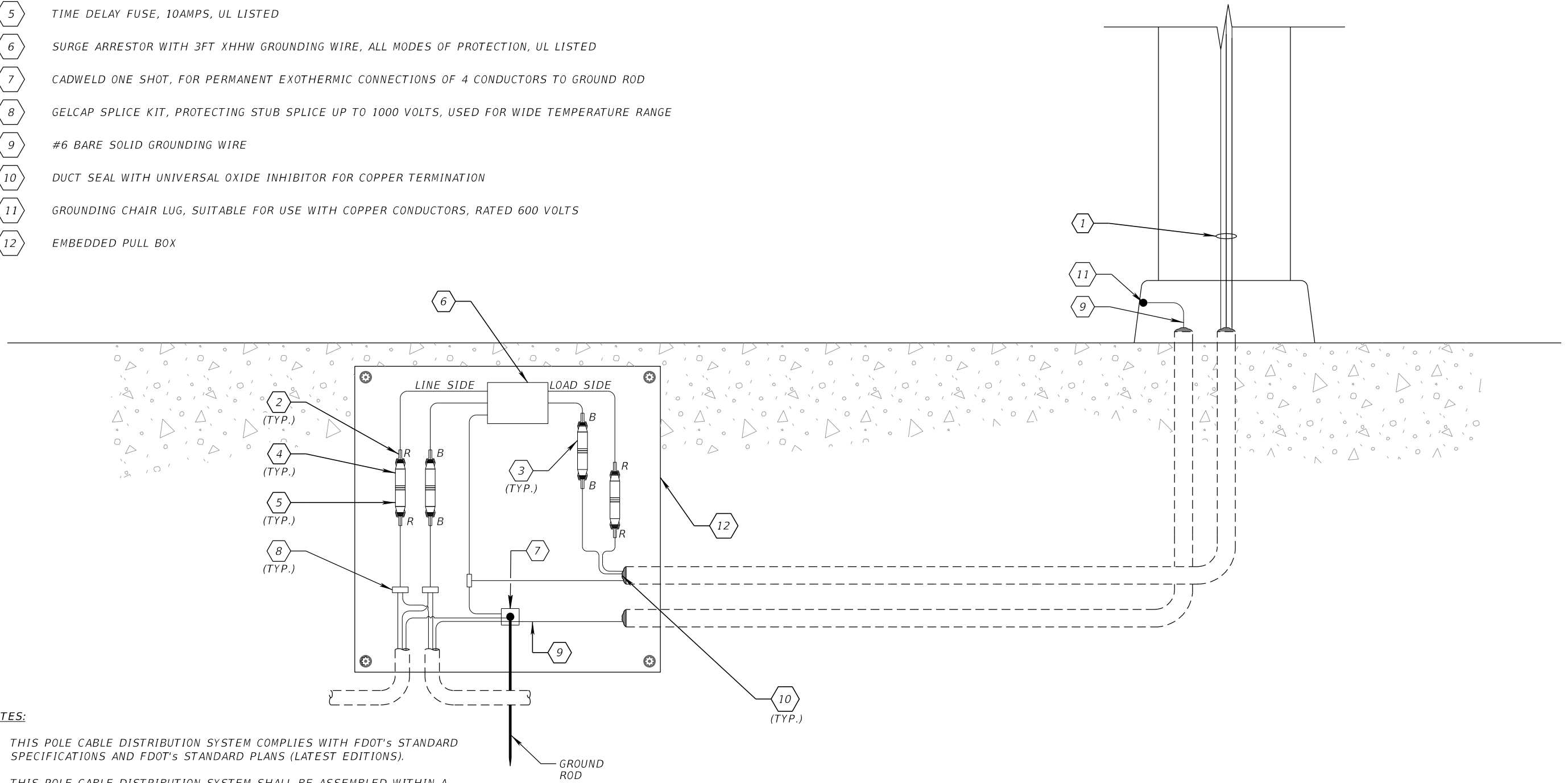

**NOTES:**

1. THIS POLE CABLE DISTRIBUTION SYSTEM COMPLIES WITH FDOT'S STANDARD SPECIFICATIONS AND FDOT'S STANDARD PLANS (LATEST EDITIONS).
2. THIS POLE CABLE DISTRIBUTION SYSTEM SHALL BE ASSEMBLED WITHIN A U.L. LISTED SHOP, PER U.L. GUIDELINES.
3. FOR MEDIAN MOUNT DUAL ARM POLES. LUMINAIRE CABLE SHALL TERMINATE TO ONE FIXTURE AND DAISY CHAIN CONDUCTORS TO FEED SECOND FIXTURE.

NOT TO SCALE

REVISIONS				ENGINEER OF RECORD FULL NAME, P.E. P.E. LICENSE NUMBER 99999 ENGINEER OF RECORD COMPANY NAME ENGINEER OF RECORD COMPANY STREET ENGINEER OF RECORD CITY, STATE AND ZIP	PROJECT NAME (1 to 3 LINES)		<b>CENTRAL FLORIDA EXPRESSWAY AUTHORITY</b>	<i>WALL MOUNT POLE CABLE DISTRIBUTION SYSTEM</i>	SHEET NO.
DATE	DESCRIPTION	DATE	DESCRIPTION		ROAD NO.	PROJECT NO.			D-2

THE OFFICIAL RECORD OF THIS SHEET IS THE ELECTRONIC FILE DIGITALLY SIGNED AND SEALED UNDER RULE 61G15-23.004, F.A.C.

W:\50088189\CFX Design Guidelines\CADD and Details\Lighting - Progress Working Files\D - Ground & Wall Mount Pole Cable Distribution System\L1\_003.dgn 3:04:29 PM 3/7/2025 ggrant@ham

**KEYED NOTES:**

- 1 10-3 TC-ER 600V XHHW-2 XLPE LUMINAIRE CABLE
- 2 HEAT SHRINK (BLACK, RED & GREEN), AT BOTH ENDS OF ALL FUSE HOLDERS, HEAVY-WALL SEALANT COATED TUBING, UL LISTED
- 3 BREAKAWAY FUSE HOLDER WITH COPPER SLUG (BLACK, RED & GREEN)
- 4 SUBMERSIBLE RATED BREAKAWAY FUSE HOLDER (BLACK, RED & GREEN)
- 5 TIME DELAY FUSE, 10 AMPS, UL LISTED
- 6 SURGE ARRESTOR WITH 3FT XHHW GROUNDING WIRE, ALL MODES OF PROTECTION, UL LISTED
- 7 CADWELD ONE SHOT KIT, FOR PERMANENT EXOTHERMIC CONNECTIONS TO GROUND ROD
- 8 GELCAP SPLICE KIT, PROTECTING STUB SPLICE UP TO 1000 VOLTS, USED FOR WIDE TEMPERATURE RANGE
- 9 #6 BARE SOLID GROUNDING WIRE
- 10 DUCT SEAL WITH UNIVERSAL OXIDE INHIBITOR FOR COPPER TERMINATION
- 11 GROUNDING CHAIR LUG, SUITABLE FOR USE WITH COPPER CONDUCTORS, RATED 600 VOLTS
- 12 EMBEDDED PULL BOX

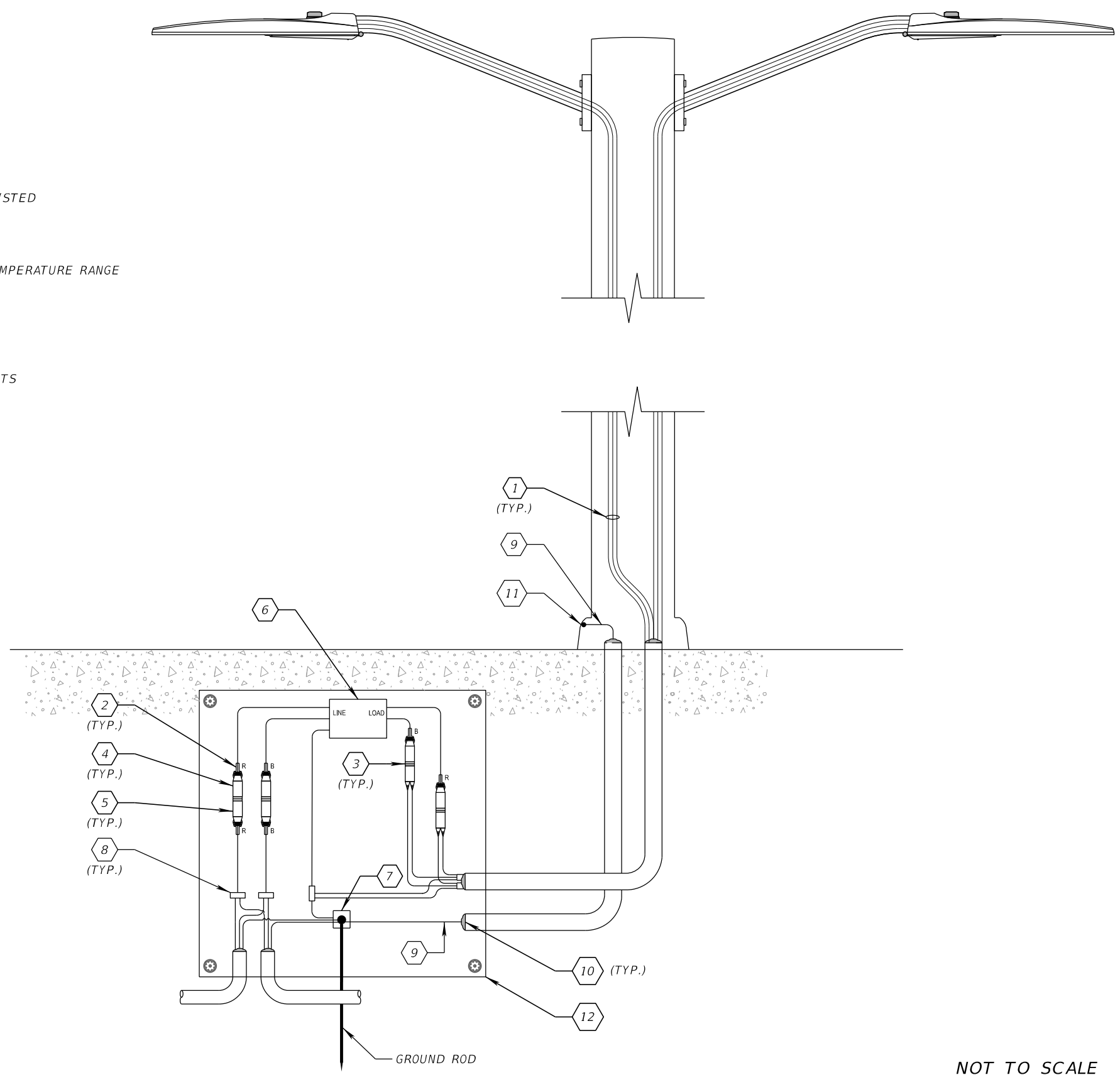

**NOTES:**

1. THIS POLE CABLE DISTRIBUTION SYSTEM COMPLIES WITH FDOT'S STANDARD SPECIFICATIONS AND FDOT'S STANDARD PLANS (LATEST EDITIONS).
2. THIS POLE CABLE DISTRIBUTION SYSTEM SHALL BE ASSEMBLED WITHIN A U.L. LISTED SHOP, PER U.L. GUIDELINES.

REVISIONS				ENGINEER OF RECORD FULL NAME, P.E. P.E. LICENSE NUMBER 99999 ENGINEER OF RECORD COMPANY NAME ENGINEER OF RECORD COMPANY STREET ENGINEER OF RECORD CITY, STATE AND ZIP	PROJECT NAME (1 to 3 LINES)		<b>CENTRAL FLORIDA EXPRESSWAY AUTHORITY</b>	<i>WALL MOUNT DOUBLE POLE CABLE DISTRIBUTION SYSTEM</i>	SHEET NO.
DATE	DESCRIPTION	DATE	DESCRIPTION		ROAD NO.	PROJECT NO.			D-3

THE OFFICIAL RECORD OF THIS SHEET IS THE ELECTRONIC FILE DIGITALLY SIGNED AND SEALED UNDER RULE 61G15-23.004, F.A.C.

W:\50088189\CFX Design Guidelines\CADD and Details\Lighting - Progress Working Files\E - LED Sign Lighting Details\LT\_E01.DGN 3:04:29 PM 3/7/2025 ggrant@ham

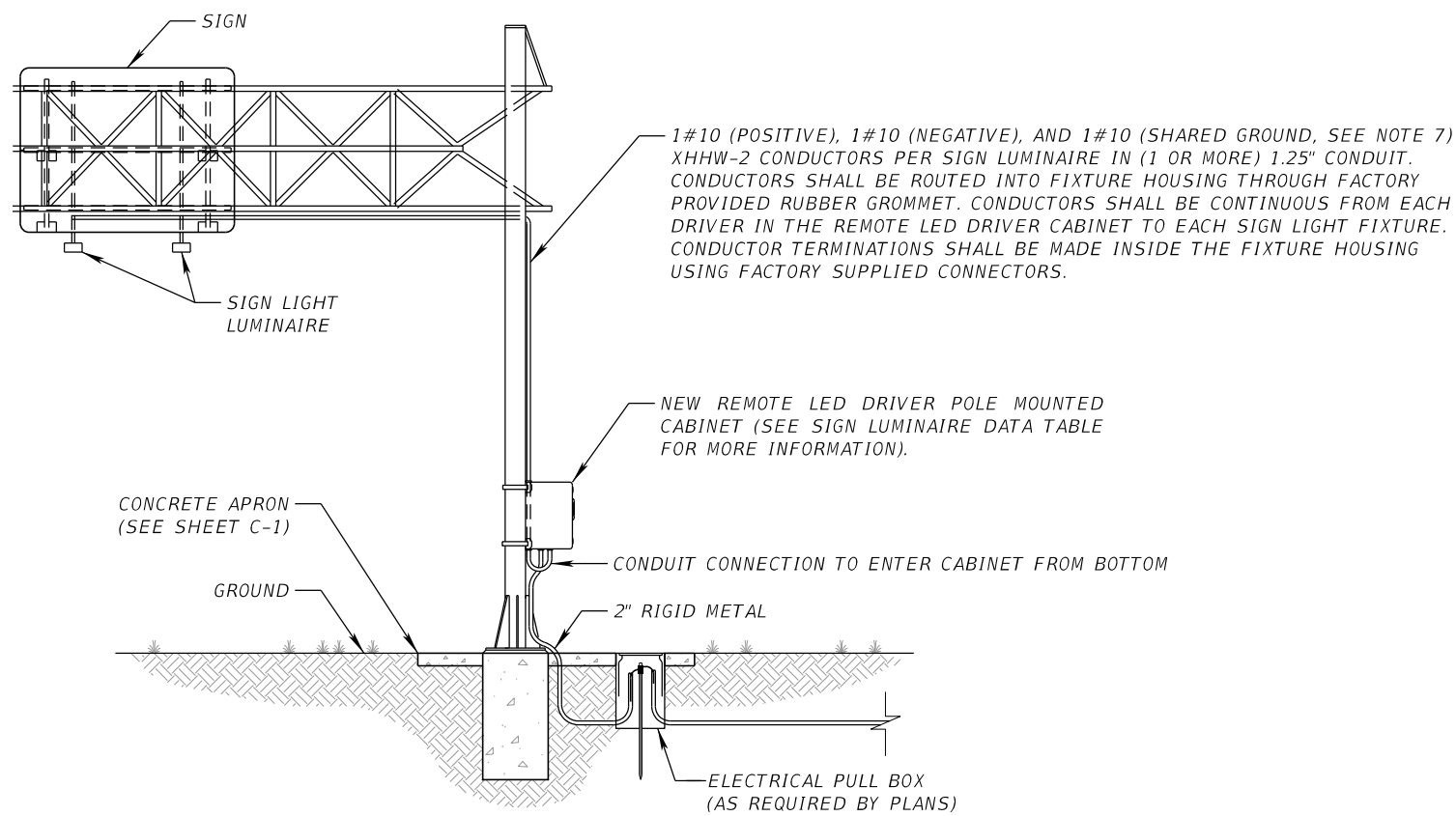

**LED SIGN LIGHT WIRING DETAIL**

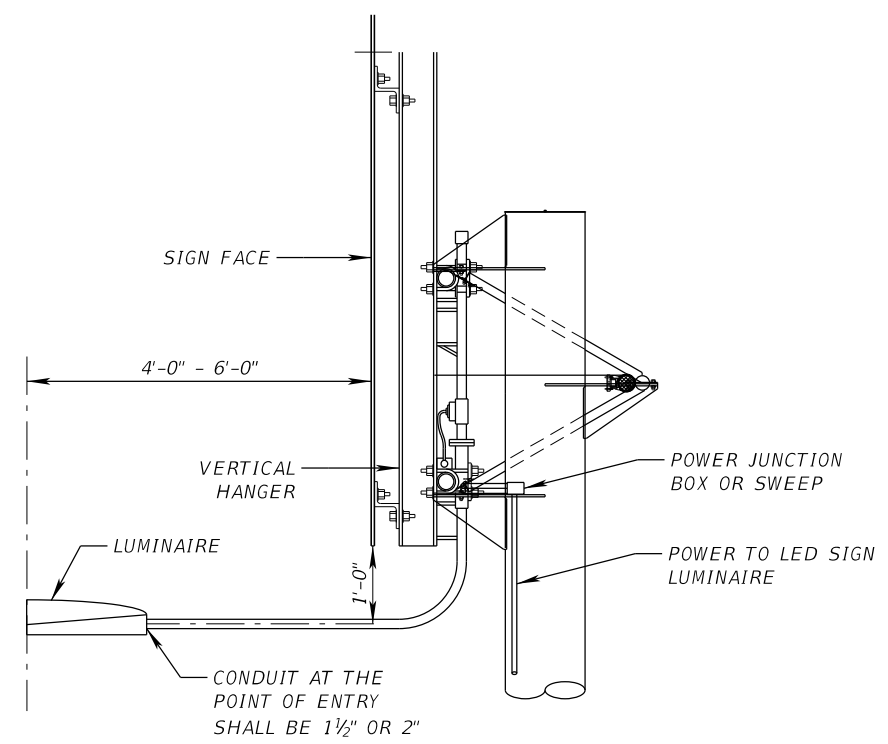

**LED SIGN LIGHT LUMINAIRE ON STRUCTURE (PROFILE)**

**SIGN LIGHTING NOTES:**

1. SIGN LUMINAIRE SHALL BE VISIONAIRE LIGHTING CLAMP ON KNUCKLE MOUNT VSX-II SERIES OR CFX APPROVED EQUAL. SIGN LUMINAIRES SHALL BE PROVIDED WITH DRIVER AND SURGE PROTECTION LOCATED REMOTELY IN REMOTE LED DRIVER CABINET MOUNTED AT THE POLE. SIGN LUMINAIRES SHALL MATCH COLOR OF STRUCTURE. TOP MOUNTED LUMINAIRES SHALL NOT BE ALLOWED ON OVERHEAD SIGN STRUCTURES ALONG ANY PORTION OF THE MAINLINE OR ON RAMPS WITHIN THE CFX JURISDICTION WITHOUT PRIOR AUTHORITY APPROVAL.
2. LUMINAIRES SHALL BE MOUNTED ONE FOOT BELOW THE BOTTOM OF SIGN PANEL AND BE FOUR TO SIX FEET OFFSET, SEE SIGN LUMINAIRE DATA FOR ARM LENGTHS. SEE FDOT DESIGN STANDARDS AND SIGN DETAIL DRAWING FOR FURTHER INFORMATION ON SIGN LIGHTING INSTALLATION. PER THE SIGN LUMINAIRE DATA TABLE, EACH LUMINAIRE WILL HAVE ONE LED DRIVER THAT WILL HELP MAINTAIN CONSTANT CURRENT OUTPUT.
3. UPON APPROVAL FROM THE ENGINEER THE SPACING MAY BE ADJUSTED BY CONTRACTOR AS NECESSARY TO ACCOMMODATE STRUCTURAL MEMBERS.
4. SIGN LIGHTING DESIGN CRITERIA BASED ON LOW TO MEDIUM AND HIGH AMBIENT LUMINANCE OF SURROUNDING AREA. REFER TO SIGN LIGHTING CRITERIA FOR ADDITIONAL INFORMATION.
5. SIGN STRUCTURES CONTAINING LUMINAIRES WITH ONE LUMINAIRE PER DRIVER UP TO THREE LED DRIVERS MUST USE (1) SMALL LED REMOTE DRIVER CABINET; BETWEEN FOUR AND SIX LED DRIVERS MUST USE (1) MEDIUM SIZE LED REMOTE DRIVER CABINET; AND BETWEEN SEVEN AND NINE LED DRIVERS MUST USE (1) LARGE LED REMOTE DRIVER CABINET. REFER TO SIGN LUMINAIRE DATA SHEET FOR ADDITIONAL INFORMATION.
6. COST OF SURFACE MOUNT CONDUIT, CONDUCTORS, AND ALL OTHER NECESSARY MATERIALS FOR A COMPLETE REMOTE LED DRIVER CABINET INSTALLATION ON NEW AND EXISTING SIGN PANELS SHALL BE INCLUDED IN THE COST OF THE NEW REMOTE LED DRIVER CABINET IN THE LIGHTING PLANS COMPONENT SET. REFER TO PAY ITEM NOTES ASSOCIATED WITH VARIOUS SIZES OF REMOTE LED DRIVER CABINETS.
7. #10 SHARED GROUNDING CONDUCTOR SHALL BE DAISY-CHAINED BETWEEN SIGN LIGHT FIXTURES AND TERMINATE TO THE MAIN GROUNDING BUS IN THE REMOTE LED DRIVER CABINET.

NOT TO SCALE

REVISIONS				ENGINEER OF RECORD FULL NAME, P.E. P.E. LICENSE NUMBER 99999 ENGINEER OF RECORD COMPANY NAME ENGINEER OF RECORD COMPANY STREET ENGINEER OF RECORD CITY, STATE AND ZIP	PROJECT NAME (1 to 3 LINES)		<b>CENTRAL FLORIDA EXPRESSWAY AUTHORITY</b>	<i>LED SIGN LIGHTING DETAILS</i>	SHEET NO.
DATE	DESCRIPTION	DATE	DESCRIPTION		ROAD NO.	PROJECT NO.			E-1

THE OFFICIAL RECORD OF THIS SHEET IS THE ELECTRONIC FILE DIGITALLY SIGNED AND SEALED UNDER RULE 61G15-23.004, F.A.C.

W:\50088189\CFX Design Guidelines\CADD and Details\Lighting\Lighting - Progress Working Files\E - LED Sign Lighting Details\LT\_E02.dgn  
 3:04:29 PM  
 3/7/2025  
 ggrant@ham

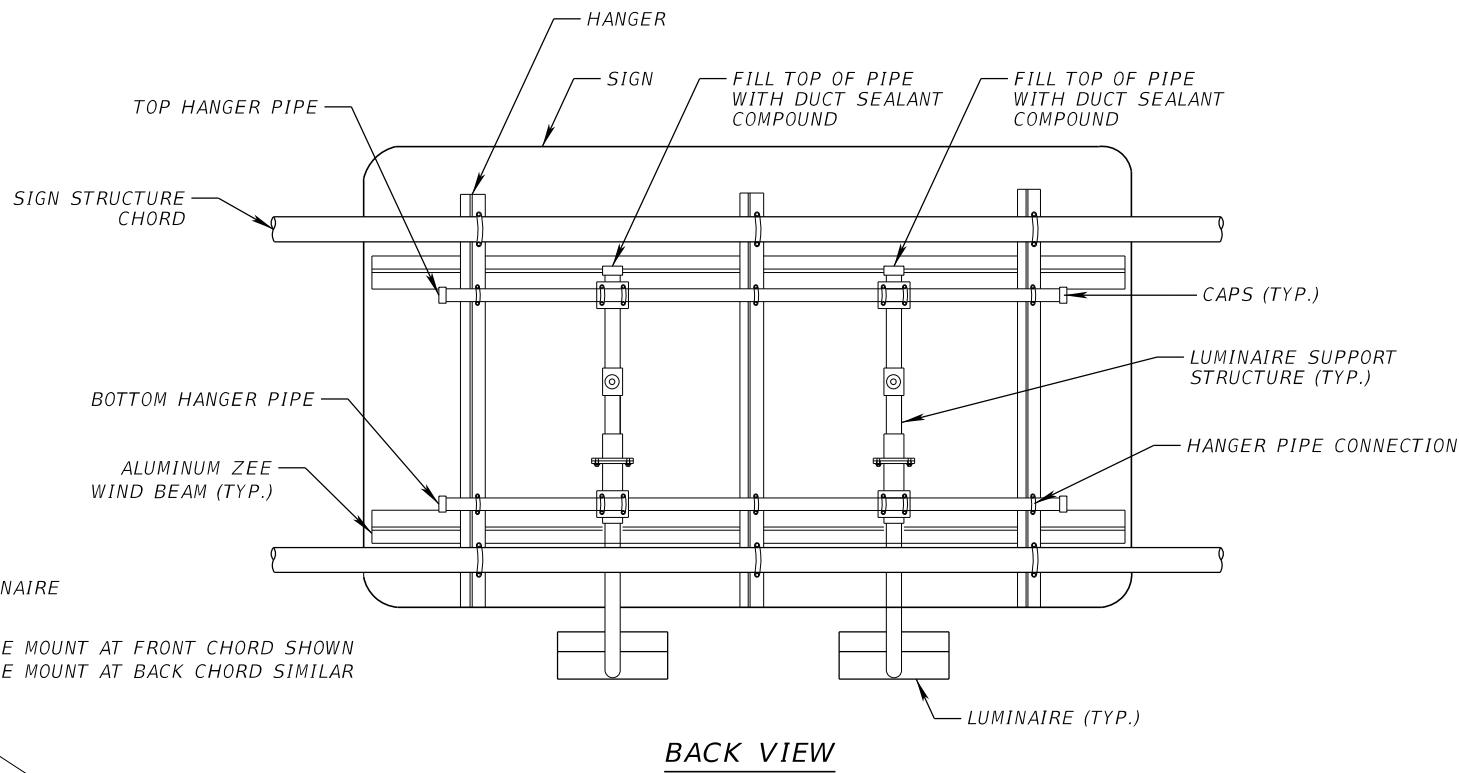
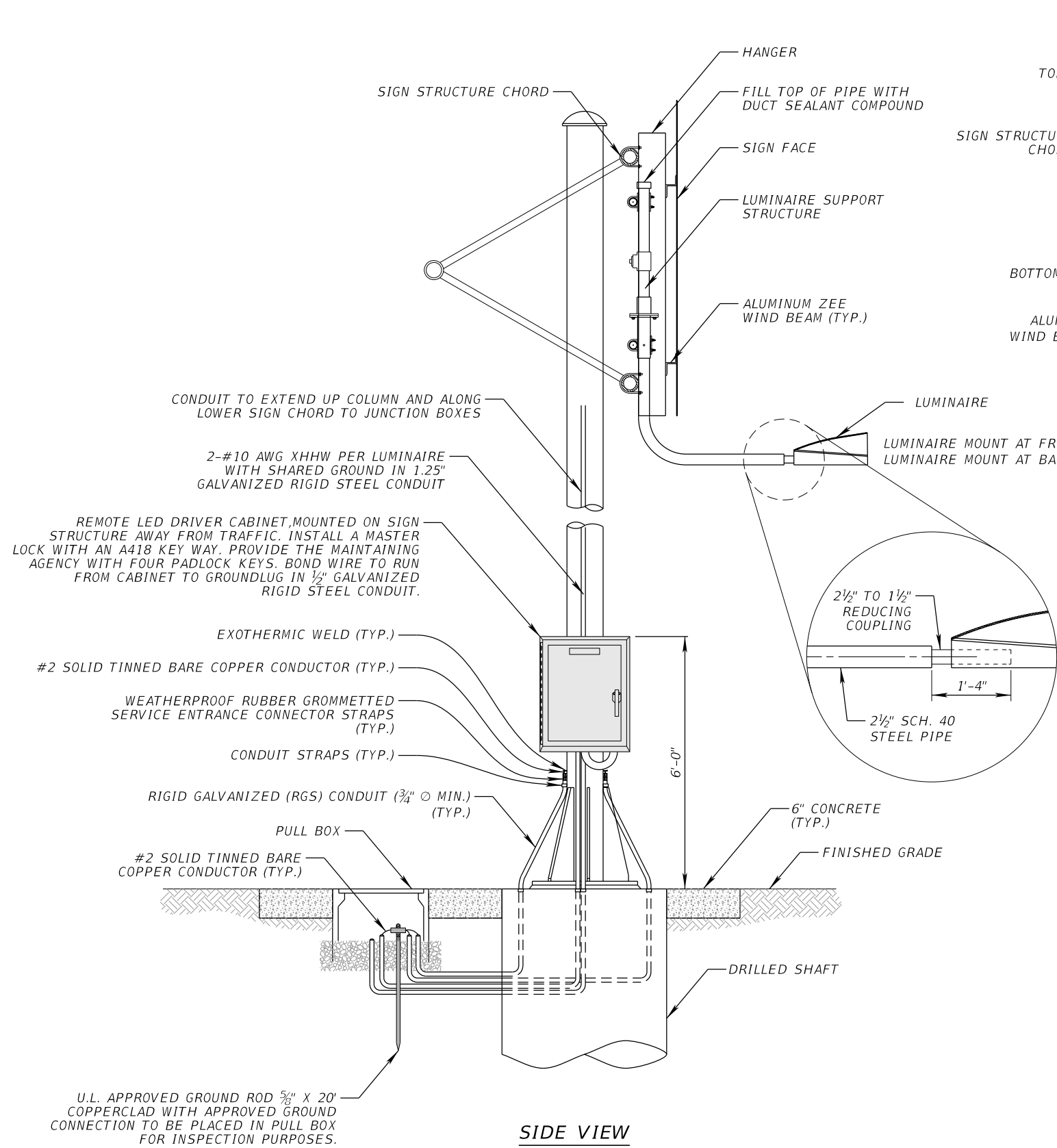

**PLACEMENT OF SIGN LIGHTS**

1. THIS INDEX DETAILS A BOTTOM LUMINAIRE SUPPORT STRUCTURE. FOR SIGNS REQUIRING TOP LUMINAIRE SUPPORT STRUCTURES, CFX APPROVAL IS REQUIRED.
2. LUMINAIRE SPACING AND ARM LENGTH IS SHOWN ON GUIDE SIGN WORKSHEET.
3. DATA TABLE INDICATES THE SIGN LUMINAIRE USED FOR BASIS OF DESIGN.

**SIGN LIGHTING INSTALLATION**

1. POWER FOR THE SIGN LIGHTING PROVIDED FROM THE ROADWAY LIGHTING CIRCUIT.
2. INDICATE SIGN LOCATION AND A PULL BOX LOCATION FOR CONNECTION TO THE SIGN LIGHTS AND REMOTE LED DRIVER CABINET IN THE LIGHTING PLANS.

**REMOTE LED DRIVER CABINET**

1. INSTALL A MASTER LOCK WITH AN A418 KEY WAY.
2. PROVIDE 4 - A418 KEYS TO CFX MAINTENANCE FOR THE ENTIRE PROJECT.

NOT TO SCALE

REVISIONS				ENGINEER OF RECORD FULL NAME, P.E. P.E. LICENSE NUMBER 99999 ENGINEER OF RECORD COMPANY NAME ENGINEER OF RECORD COMPANY STREET ENGINEER OF RECORD CITY, STATE AND ZIP	PROJECT NAME (1 to 3 LINES)			SHEET NO.  E-2
DATE	DESCRIPTION	DATE	DESCRIPTION		ROAD NO.	PROJECT NO.		
							<b>LED SIGN LIGHTING DETAILS</b>	

THE OFFICIAL RECORD OF THIS SHEET IS THE ELECTRONIC FILE DIGITALLY SIGNED AND SEALED UNDER RULE 61G15-23.004, F.A.C.

W:\50088189\CFX Design Guidelines\CADD and Details\Lighting -Progress Working Files\E - LED Sign Lighting Details\LT\_E03.dgn  
 3:04:30 PM  
 3/7/2025  
 ggrant@ham

## TILT

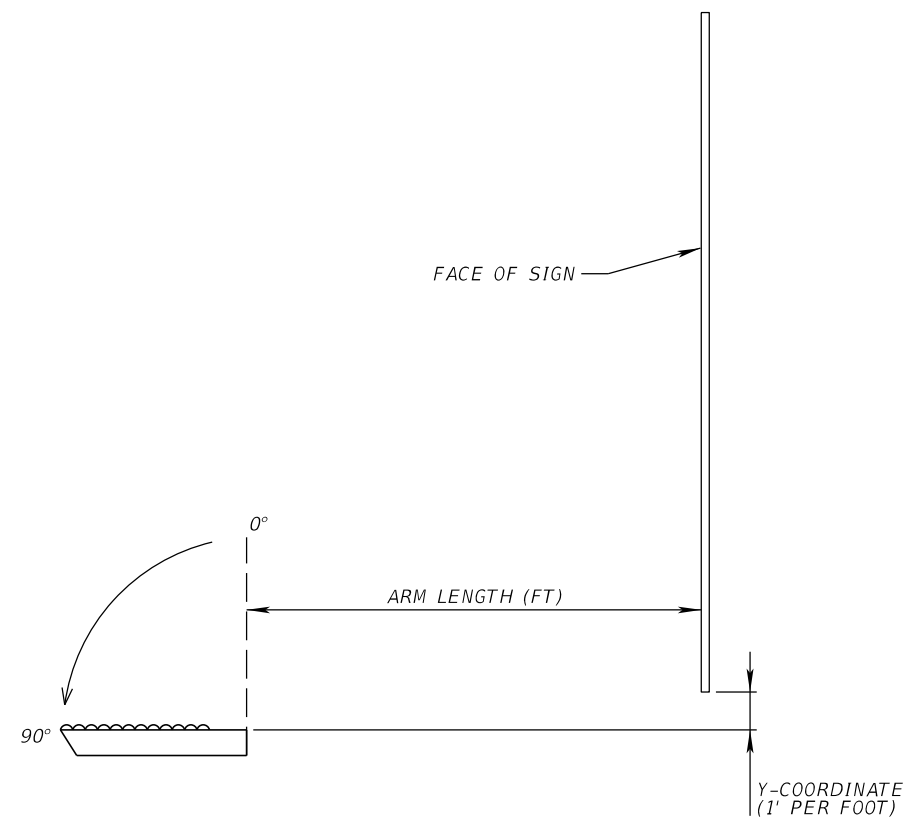

NOT TO SCALE

REVISIONS				PROJECT NAME (1 to 3 LINES)		<b>CENTRAL FLORIDA EXPRESSWAY AUTHORITY</b>	<i>SIGN LIGHTING TILT ANGLE DETAIL</i>		SHEET NO.
DATE	DESCRIPTION	DATE	DESCRIPTION	ROAD NO.	PROJECT NO.				E-3
				ENGINEER OF RECORD FULL NAME, P.E. P.E. LICENSE NUMBER 99999 ENGINEER OF RECORD COMPANY NAME ENGINEER OF RECORD COMPANY STREET ENGINEER OF RECORD CITY, STATE AND ZIP					

THE OFFICIAL RECORD OF THIS SHEET IS THE ELECTRONIC FILE DIGITALLY SIGNED AND SEALED UNDER RULE 61G15-23.004, F.A.C.

W:\50088189\CFX Design Guidelines\CADD and Details\Lighting - Progress Working Files\F - Underdeck Lighting\LT\_F01.DGN  
 3:04:30 PM  
 3/7/2025  
 ggrant@ham

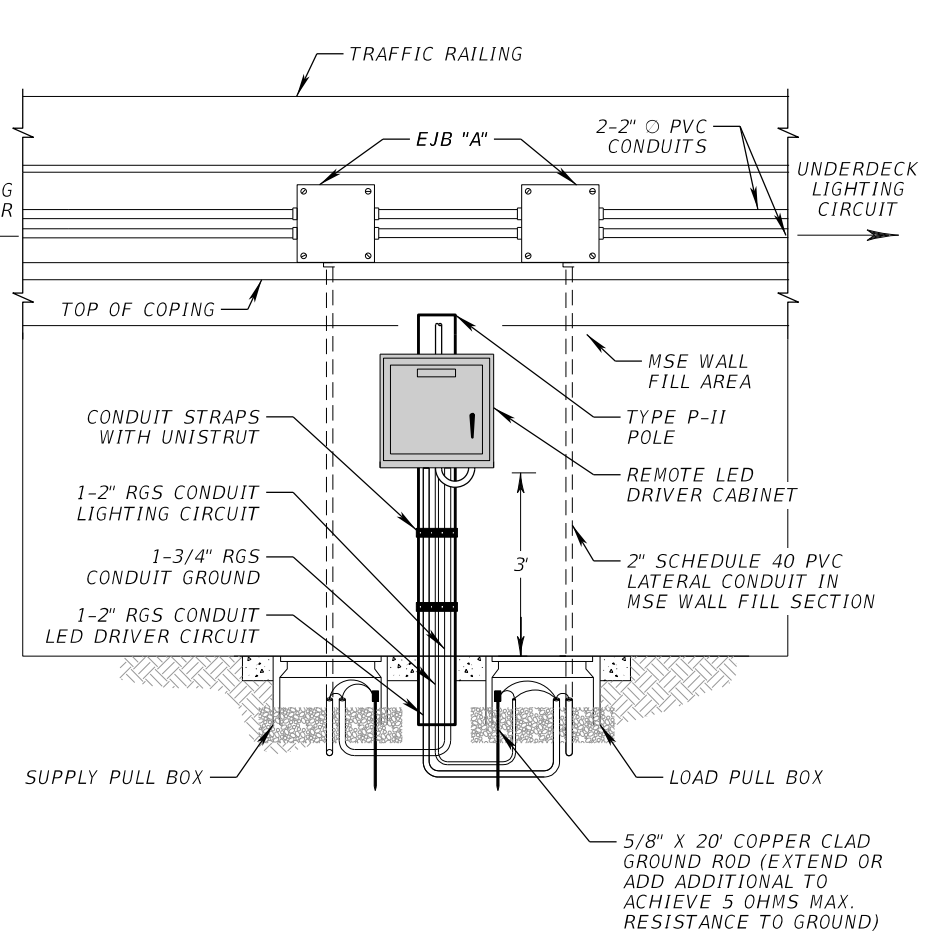
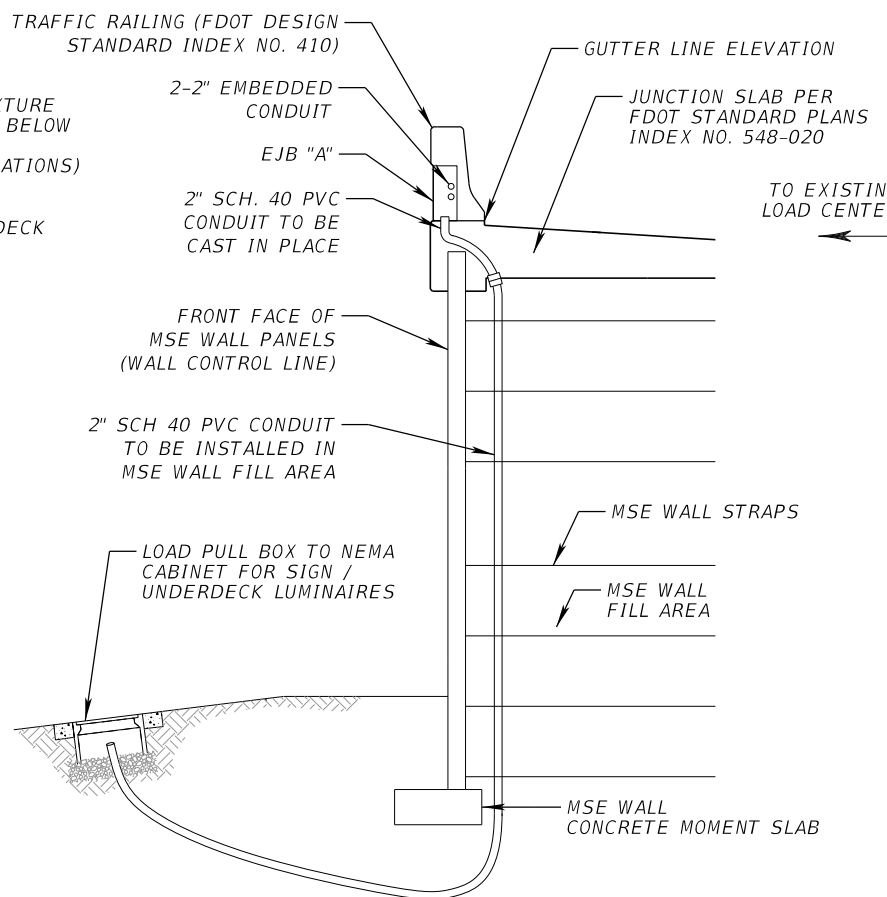
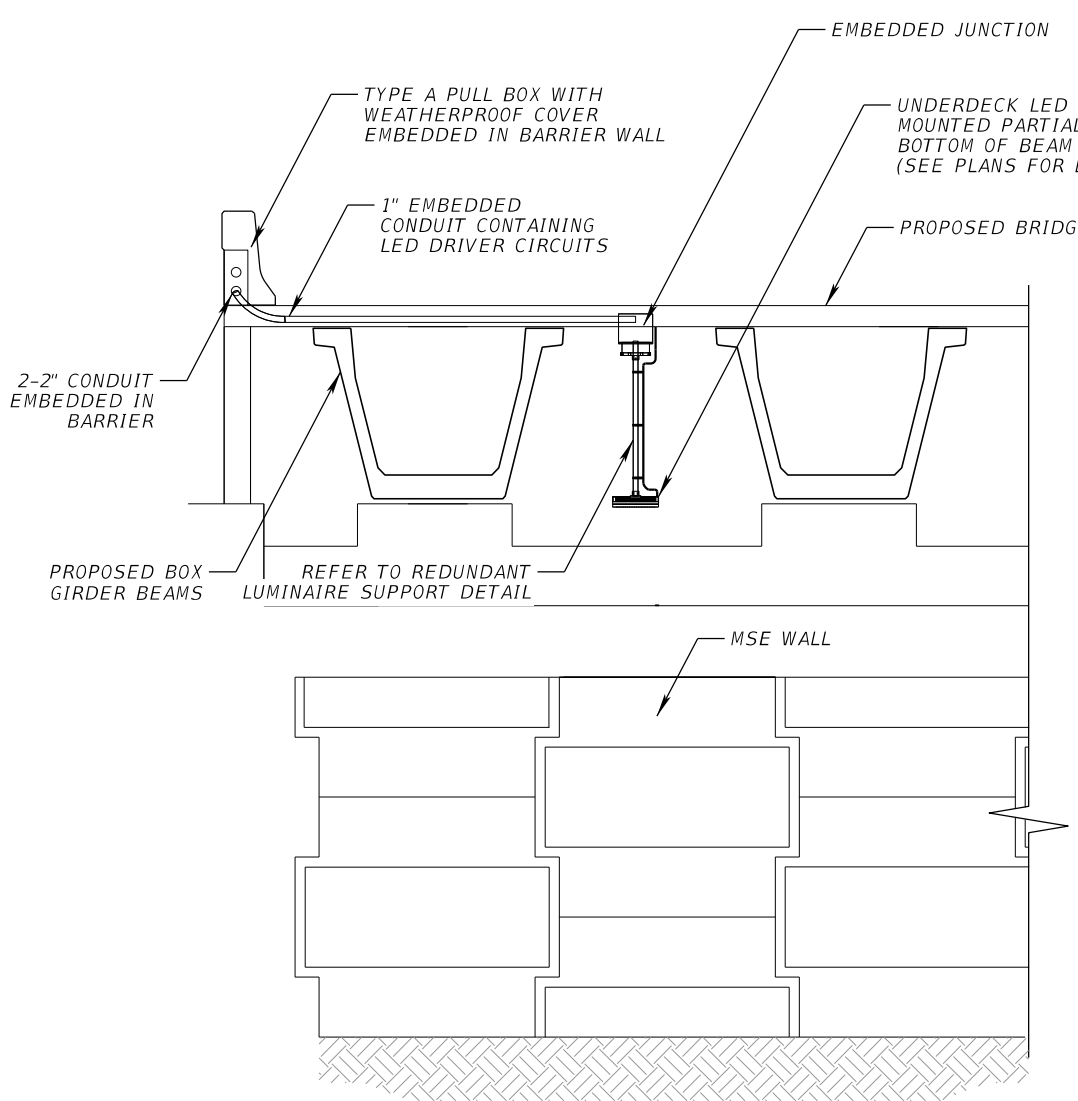

**PENDANT HUNG UNDERDECK LIGHTING DETAIL  
PROPOSED BRIDGE TYPICAL**

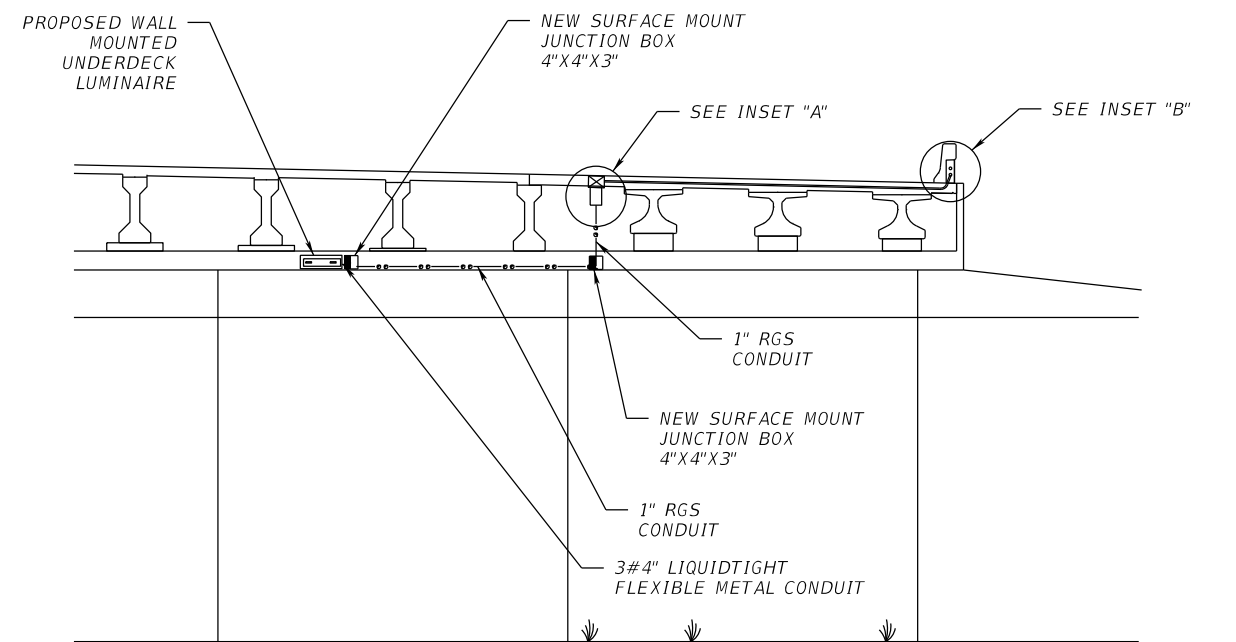

**WALL PACK UNDERDECK LIGHTING DETAIL  
PROPOSED BRIDGE TYPICAL**

NOT TO SCALE

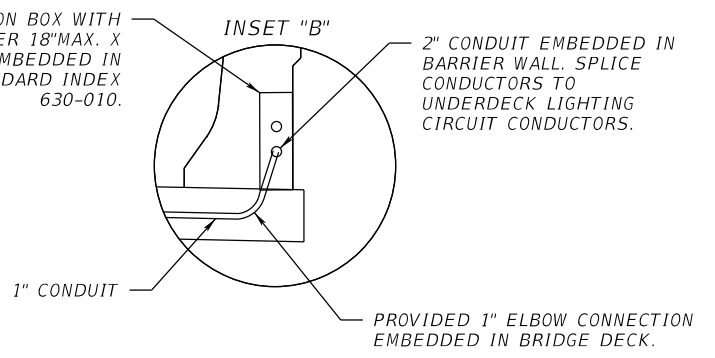
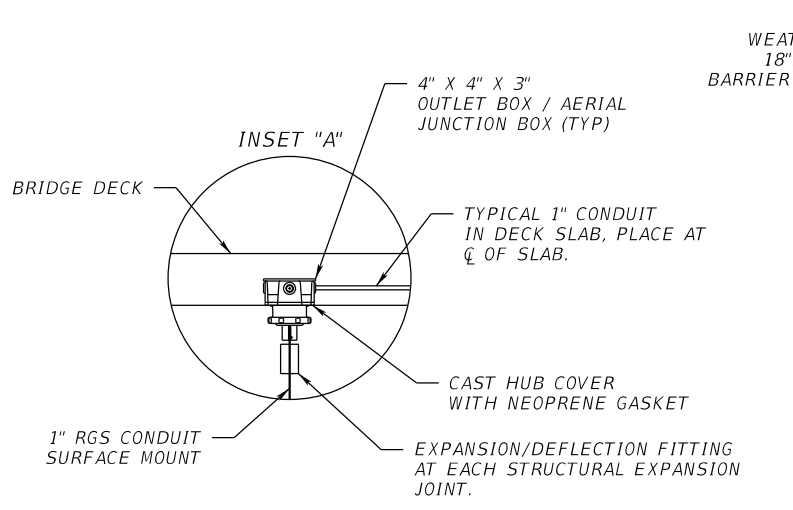

REVISIONS			
DATE	DESCRIPTION	DATE	DESCRIPTION

ENGINEER OF RECORD FULL NAME, P.E.  
 P.E. LICENSE NUMBER 99999  
 ENGINEER OF RECORD COMPANY NAME  
 ENGINEER OF RECORD COMPANY STREET  
 ENGINEER OF RECORD CITY, STATE AND ZIP

PROJECT NAME  
 (1 to 3 LINES)  
 ROAD NO. PROJECT NO.



**UNDERDECK LIGHTING  
MOUNTING DETAILS**  
 SHEET NO. F-1

THE OFFICIAL RECORD OF THIS SHEET IS THE ELECTRONIC FILE DIGITALLY SIGNED AND SEALED UNDER RULE 61G15-23.004, F.A.C.

3/7/2025 3:04:30 PM W:\50088189\CFX Design Guidelines\CADD and Details\Lighting - Progress Working Files\F - Underdeck Lighting\LT\_F02.DGN ggrant\ham

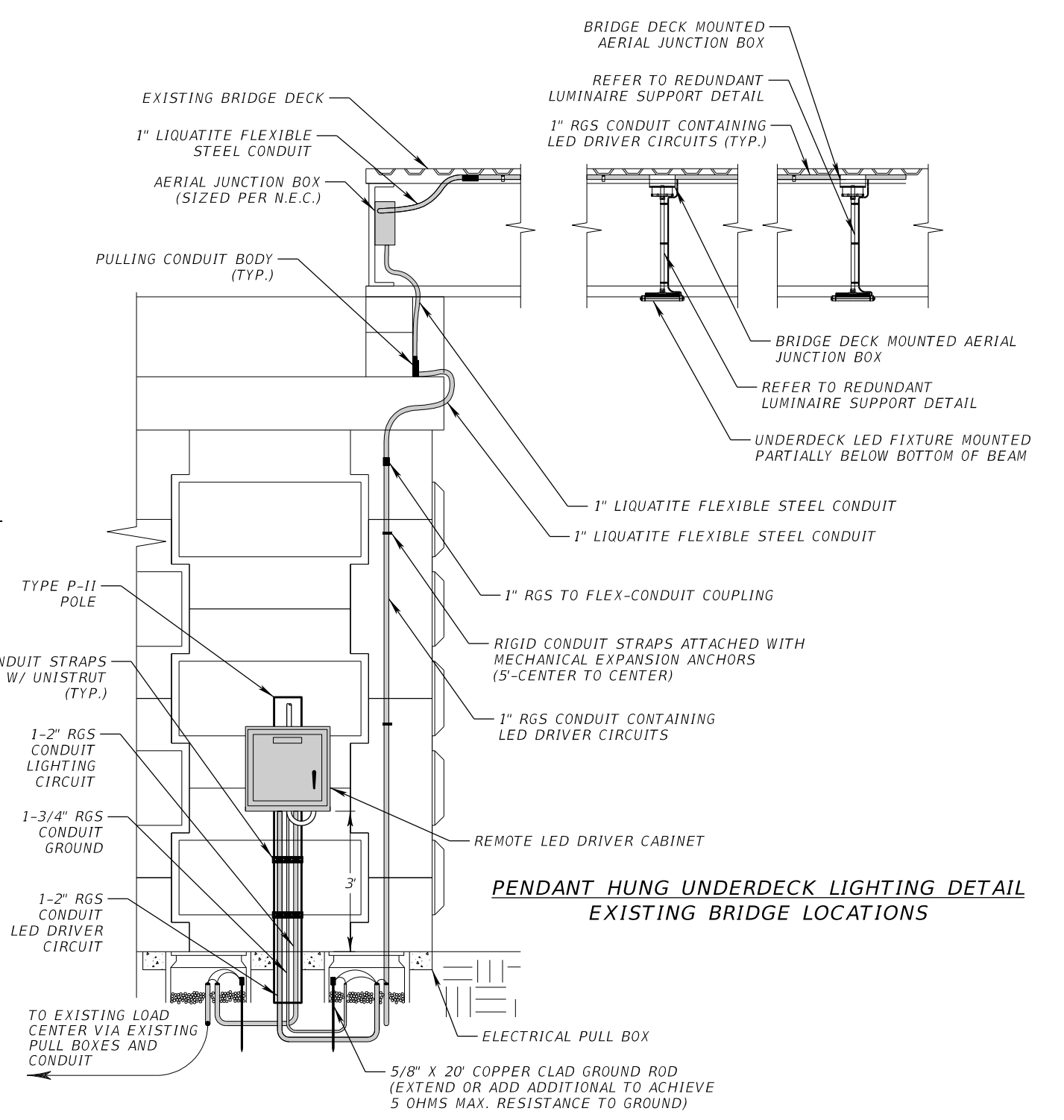
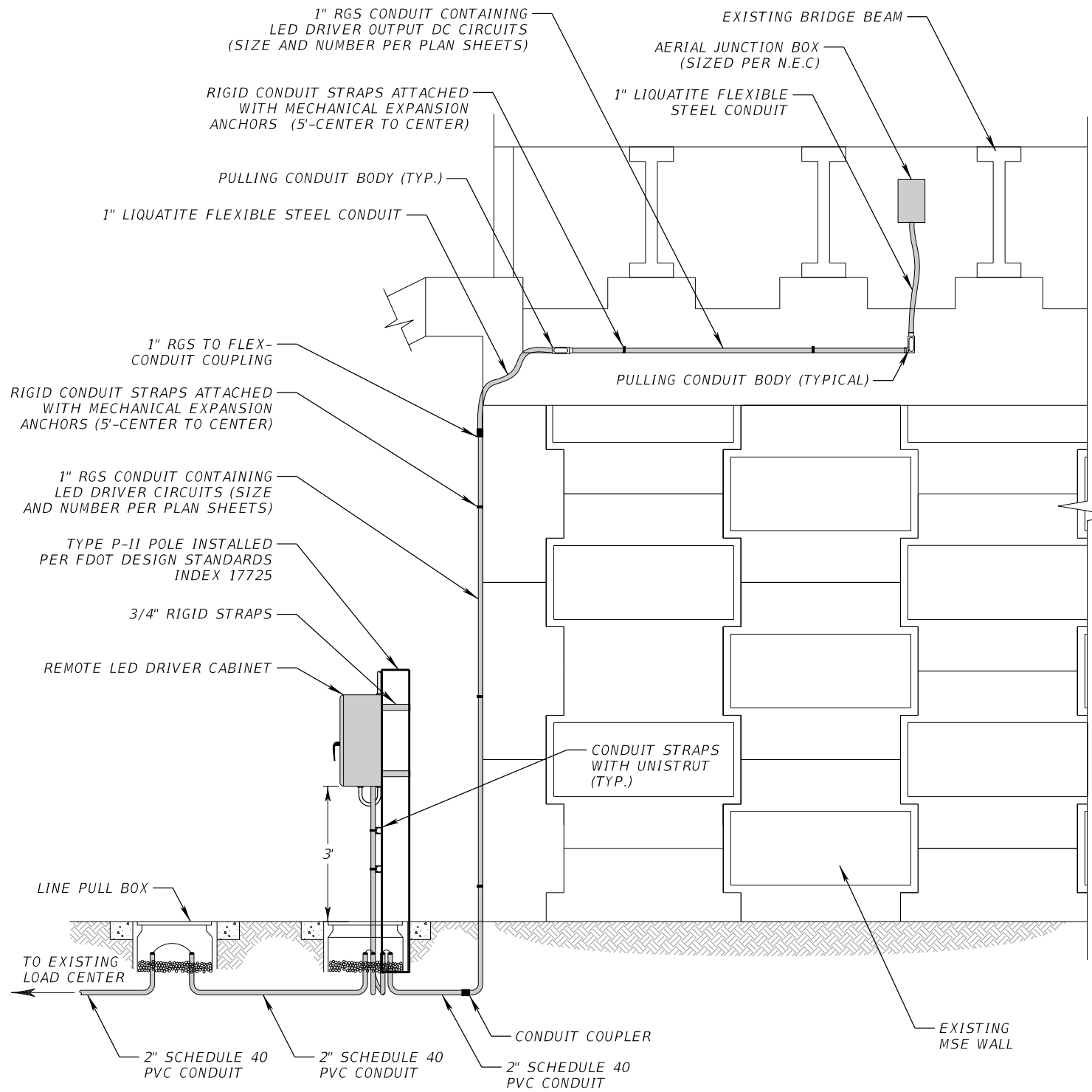

**NOTES:**

1. ALL ATTACHMENT HARDWARE SHALL BE RIGID STEEL UNLESS OTHERWISE SPECIFIED.
2. ENSURE ALL ELEMENTS ARE BONDED AND GROUNDED PER N.E.C. REQUIREMENTS.
3. ALL CONDUIT ATTACHMENTS TO COUPLERS, EQUIPMENT ENCLOSURES (CABINETS), AND PULLING ELBOWS SHALL BE WEATHER TIGHT.
4. THE ENGINEER SHALL DESIGN AND DETAIL THE CONNECTION AND BRACING FOR THE UNDERDECK LUMINAIRE HANGING CONDUIT AND JUNCTION BOX, AND THE JUNCTION BOX ITSELF, IN ACCORDANCE WITH THE MOST RECENT VERSION OF AASHTO 'STANDARD SPECIFICATIONS FOR STRUCTURAL SUPPORTS FOR HIGHWAY SIGNS, LUMINAIRES AND TRAFFIC SIGNALS.
5. THE SURFACE MOUNT CONDUIT, MOUNTING HARDWARE, EXPANSION JOINTS, AND ANY ANCILLARY COMPONENTS NEEDED FOR A COMPLETE INSTALLATION MUST BE PAINT MATCHED TO EXISTING BRIDGE DECK AND OR MSE WALLS, IF APPLICABLE.
6. CONTRACTOR SHALL SUBMIT SHOP DRAWINGS FOR REDUNDANT SUPPORT TO LUMINAIRE AND DECK. SHOP DRAWINGS SHALL DETAIL HOW CABLE WILL PREVENT LUMINAIRE FROM FALLING IF THE CONDUIT SUPPORT WERE TO FAIL. REFER TO REDUNDANT LUMINAIRE SUPPORT DETAIL FOR ADDITIONAL INFORMATION.
7. FABRICATION SHALL NOT BEGIN UNTIL SHOP DRAWINGS ARE APPROVED.
8. FURNISH AND INSTALL NEMA TYPE 4X (NON-METALLIC) AERIAL JUNCTION BOXES SIZED IN CONFORMANCE WITH THE NEC.
9. PRIOR TO INSTALLATION, THE CONTRACTOR SHALL SUBMIT TO CFX FOR APPROVAL A SURFACE MOUNT CONDUIT SCHEMATIC FOR ALL LOCATIONS. THE SCHEMATIC SHALL DETAIL THE PROPOSED TYPE AND ROUTING OF SURFACE MOUNT CONDUIT INCLUDING LOCATIONS OF JUNCTION BOXES, EXPANSION JOINTS, AND ANY ANCILLARY COMPONENT NEEDED FOR A COMPLETE INSTALLATION.

NOT TO SCALE

REVISIONS				ENGINEER OF RECORD FULL NAME, P.E. P.E. LICENSE NUMBER 99999 ENGINEER OF RECORD COMPANY NAME ENGINEER OF RECORD COMPANY STREET ENGINEER OF RECORD CITY, STATE AND ZIP	PROJECT NAME (1 to 3 LINES)		<b>CENTRAL FLORIDA EXPRESSWAY AUTHORITY</b>	<i>UNDERDECK LIGHTING MOUNTING DETAILS</i>	SHEET NO.  F-2
DATE	DESCRIPTION	DATE	DESCRIPTION		ROAD NO.	PROJECT NO.			

THE OFFICIAL RECORD OF THIS SHEET IS THE ELECTRONIC FILE DIGITALLY SIGNED AND SEALED UNDER RULE 61G15-23.004, F.A.C.



3/7/2025 3:04:31 PM W:\50088189\CFX Design Guidelines\CADD and Details\Lighting - Progress Working Files\F - Underdeck Lighting\LT\_F03.DWG gprantham

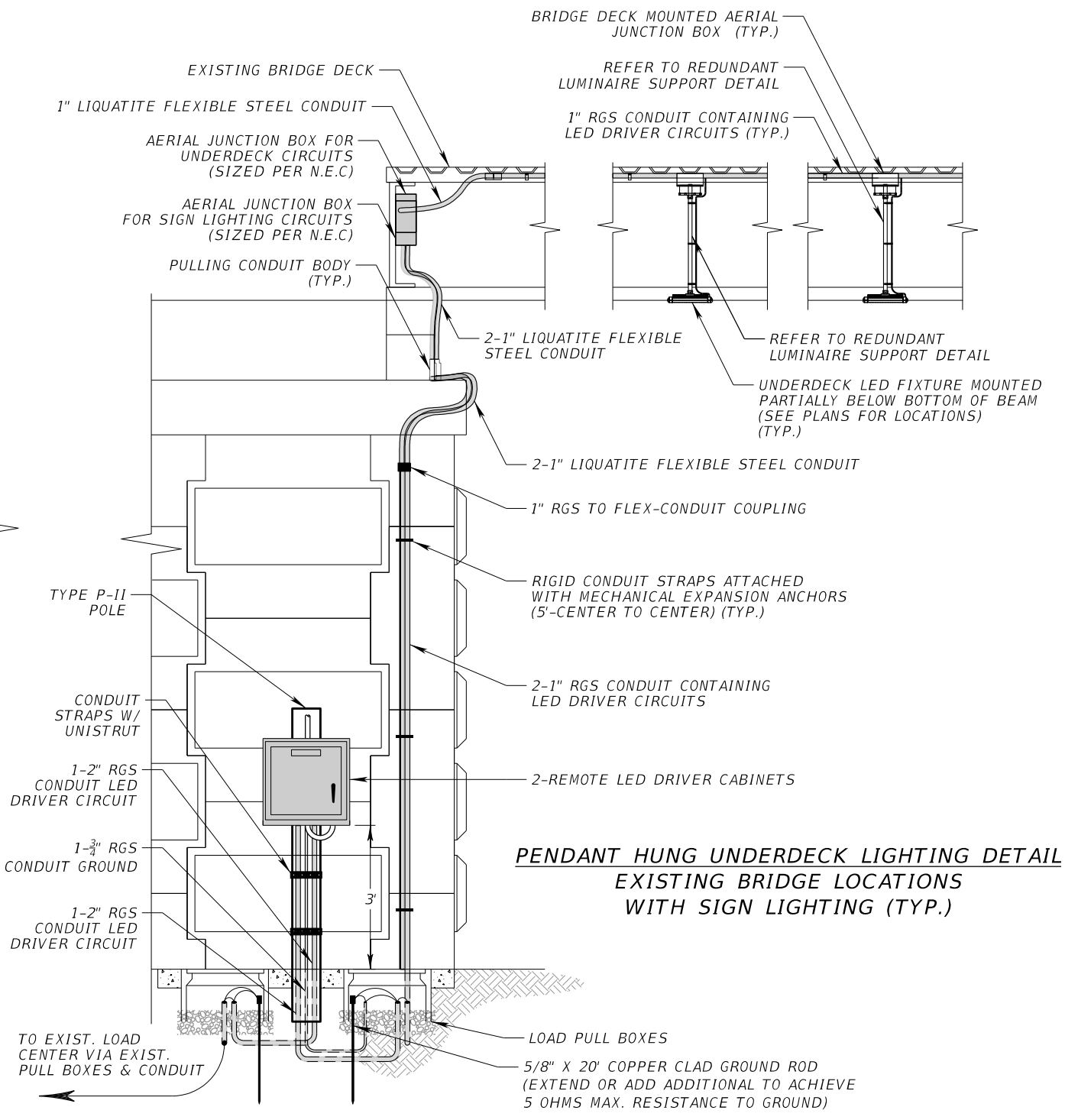
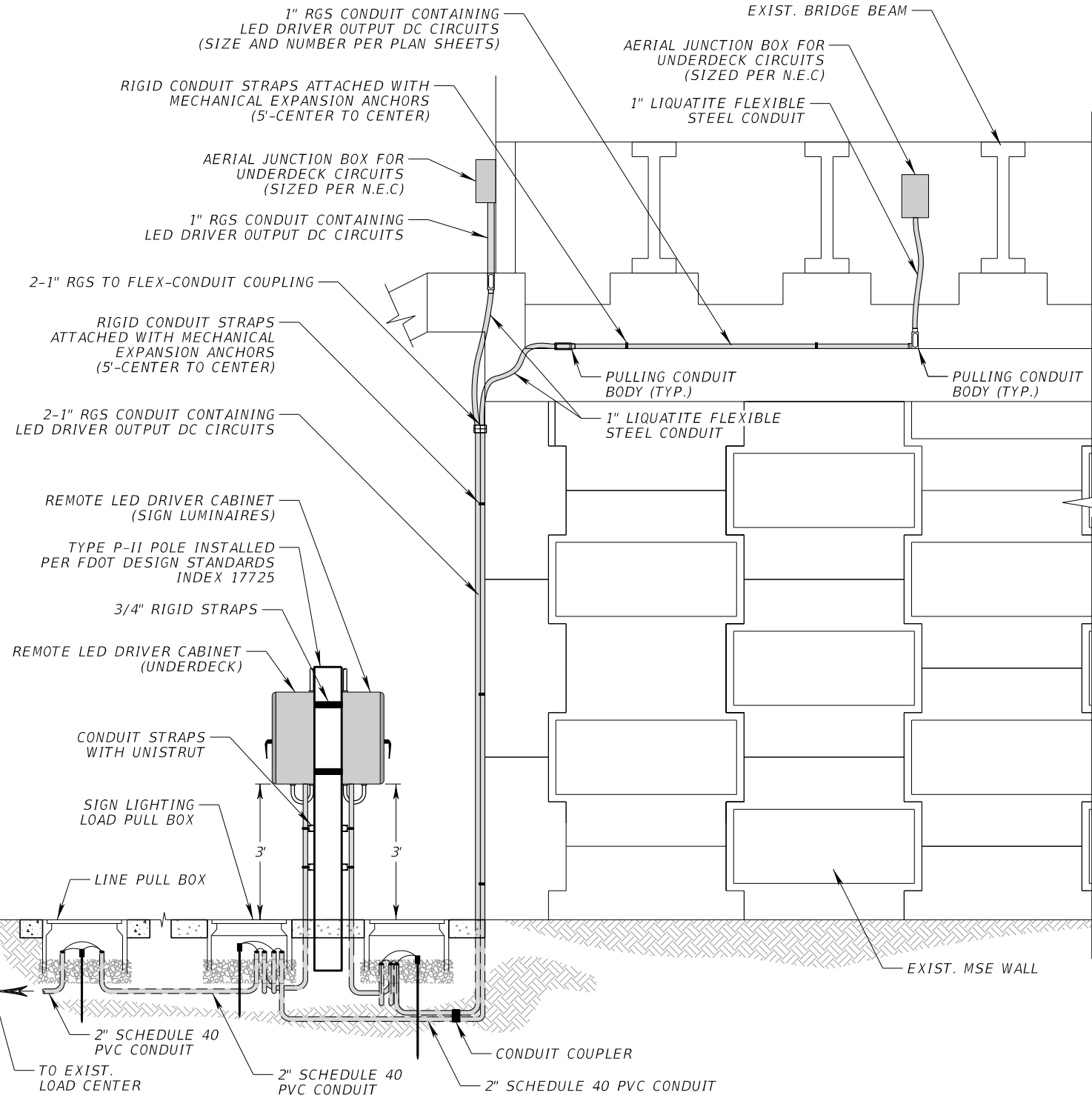

- NOTES:**
1. ALL ATTACHMENT HARDWARE SHALL BE RIGID STEEL UNLESS OTHERWISE SPECIFIED.
  2. ENSURE ALL ELEMENTS ARE BONDED AND GROUNDED PER N.E.C. REQUIREMENTS.
  3. ALL CONDUIT ATTACHMENTS TO COUPLERS, EQUIPMENT ENCLOSURES (CABINETS), AND PULLING ELBOWS SHALL BE WEATHER TIGHT.
  4. THE ENGINEER SHALL DESIGN AND DETAIL THE CONNECTION AND BRACING FOR THE UNDERDECK LUMINAIRE HANGING CONDUIT AND JUNCTION BOX, AND THE JUNCTION BOX ITSELF, IN ACCORDANCE WITH THE MOST RECENT VERSION OF AASHTO 'STANDARD SPECIFICATIONS FOR STRUCTURAL SUPPORTS FOR HIGHWAY SIGNS, LUMINAIRES AND TRAFFIC SIGNALS.

NOT TO SCALE

5. THE SURFACE MOUNT CONDUIT, MOUNTING HARDWARE, EXPANSION JOINTS, AND ANY ANCILLARY COMPONENTS NEEDED FOR A COMPLETE INSTALLATION MUST BE PAINT MATCHED TO EXISTING BRIDGE DECK AND OR MSE WALLS, IF APPLICABLE.
6. CONTRACTOR SHALL SUBMIT SHOP DRAWINGS FOR REDUNDANT SUPPORT TO LUMINAIRE AND DECK. SHOP DRAWINGS SHALL DETAIL HOW CABLE WILL PREVENT LUMINAIRE FROM FALLING IF THE CONDUIT SUPPORT WERE TO FAIL. REFER TO REDUNDANT LUMINAIRE SUPPORT DETAIL FOR ADDITIONAL INFORMATION.
7. FABRICATION SHALL NOT BEGIN UNTIL SHOP DRAWINGS ARE APPROVED.
8. FURNISH AND INSTALL NEMA TYPE 4X (NON-METALLIC) AERIAL JUNCTION BOXES SIZED IN CONFORMANCE WITH THE NEC.
9. PRIOR TO INSTALLATION, THE CONTRACTOR SHALL SUBMIT TO CFX FOR APPROVAL A SURFACE MOUNT CONDUIT SCHEMATIC FOR ALL LOCATIONS. THE SCHEMATIC SHALL DETAIL THE PROPOSED TYPE AND ROUTING OF SURFACE MOUNT CONDUIT, INCLUDING LOCATIONS OF JUNCTION BOXES, EXPANSION JOINTS, AND ANY ANCILLARY COMPONENTS NEEDED FOR A COMPLETE INSTALLATION.

REVISIONS		ENGINEER OF RECORD FULL NAME, P.E. P.E. LICENSE NUMBER 99999 ENGINEER OF RECORD COMPANY NAME ENGINEER OF RECORD COMPANY STREET ENGINEER OF RECORD CITY, STATE AND ZIP	PROJECT NAME (1 to 3 LINES)	CENTRAL FLORIDA EXPRESSWAY AUTHORITY	UNDERDECK & SIGN LIGHTING MOUNTING DETAILS	SHEET NO.  F-3
DATE	DESCRIPTION					
			ROAD NO.	PROJECT NO.		

THE OFFICIAL RECORD OF THIS SHEET IS THE ELECTRONIC FILE DIGITALLY SIGNED AND SEALED UNDER RULE 61G15-23.004, F.A.C.

W:\50088189\CFX Design Guidelines\CADD and Details\Lighting - Progress Working Files\F - Underdeck Lighting\LT\_F04.DGN  
 3:04:31 PM  
 3/7/2025  
 ggrant@ham

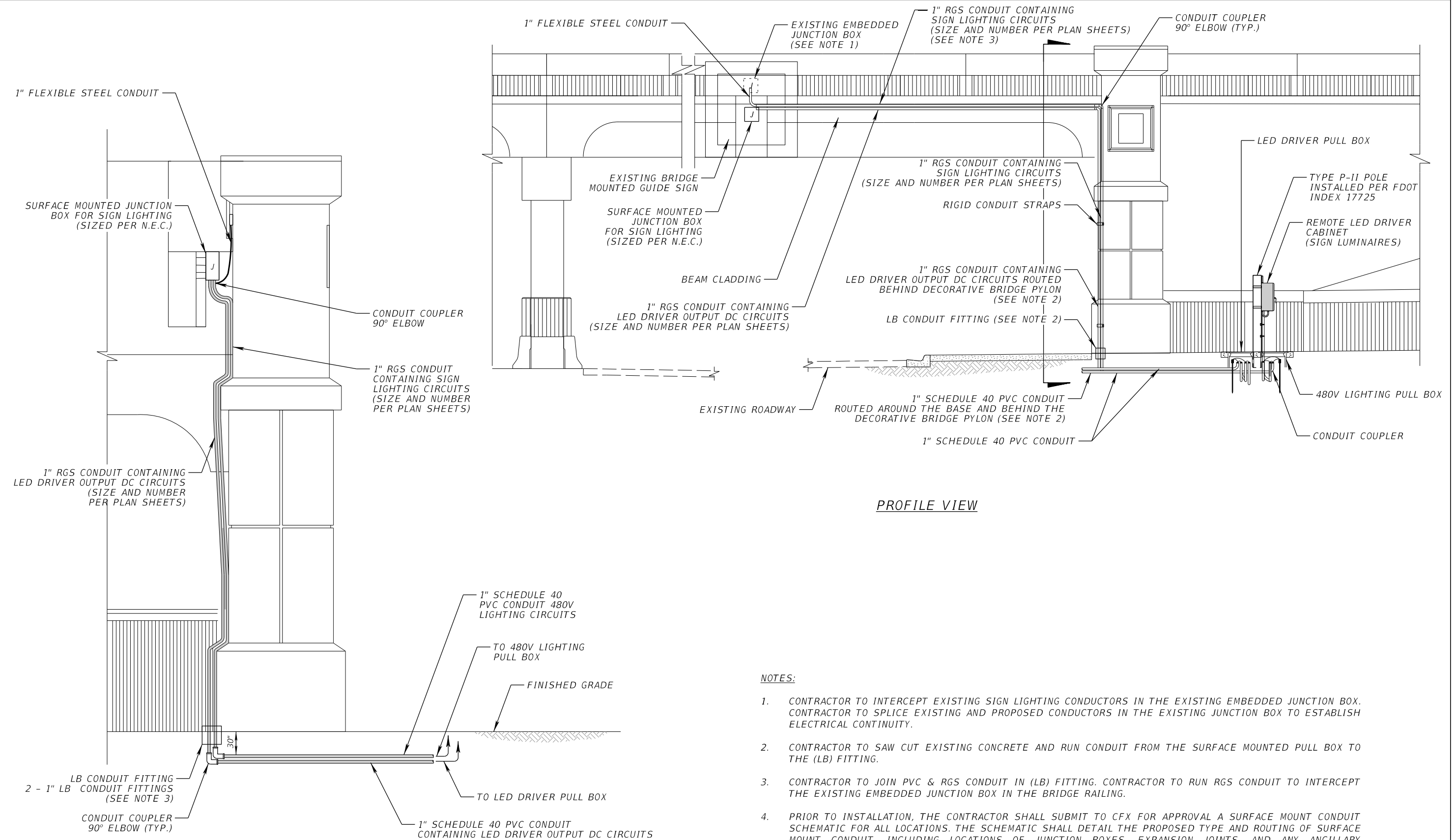

**PROFILE VIEW**

**SIDE VIEW**

- NOTES:**
- CONTRACTOR TO INTERCEPT EXISTING SIGN LIGHTING CONDUCTORS IN THE EXISTING EMBEDDED JUNCTION BOX. CONTRACTOR TO SPLICE EXISTING AND PROPOSED CONDUCTORS IN THE EXISTING JUNCTION BOX TO ESTABLISH ELECTRICAL CONTINUITY.
  - CONTRACTOR TO SAW CUT EXISTING CONCRETE AND RUN CONDUIT FROM THE SURFACE MOUNTED PULL BOX TO THE (LB) FITTING.
  - CONTRACTOR TO JOIN PVC & RGS CONDUIT IN (LB) FITTING. CONTRACTOR TO RUN RGS CONDUIT TO INTERCEPT THE EXISTING EMBEDDED JUNCTION BOX IN THE BRIDGE RAILING.
  - PRIOR TO INSTALLATION, THE CONTRACTOR SHALL SUBMIT TO CFX FOR APPROVAL A SURFACE MOUNT CONDUIT SCHEMATIC FOR ALL LOCATIONS. THE SCHEMATIC SHALL DETAIL THE PROPOSED TYPE AND ROUTING OF SURFACE MOUNT CONDUIT, INCLUDING LOCATIONS OF JUNCTION BOXES, EXPANSION JOINTS, AND ANY ANCILLARY COMPONENTS NEEDED FOR A COMPLETE INSTALLATION.

NOT TO SCALE

REVISIONS				ENGINEER OF RECORD FULL NAME, P.E. P.E. LICENSE NUMBER 99999 ENGINEER OF RECORD COMPANY NAME ENGINEER OF RECORD COMPANY STREET ENGINEER OF RECORD CITY, STATE AND ZIP	PROJECT NAME (1 to 3 LINES)			<b>BRIDGE MOUNTED SIGN LIGHTING MOUNTING DETAIL</b>	SHEET NO.  F-4
DATE	DESCRIPTION	DATE	DESCRIPTION		ROAD NO.	PROJECT NO.			

THE OFFICIAL RECORD OF THIS SHEET IS THE ELECTRONIC FILE DIGITALLY SIGNED AND SEALED UNDER RULE 61G15-23.004, F.A.C.

3/7/2025 3:04:31 PM W:\50088189\CFX Design Guidelines\CADD and Details\Lighting\Lighting - Progress Working Files\F - Underdeck Lighting\LT\_F05.DGN

CABLE ATTACHED WITH ONE M10 HDA-PR STAINLESS STEEL UNDERCUT ANCHOR. CABLE MAY BE ATTACHED TO TOP OR BOTTOM OF SIP FORM FLUTES, 3.9" EMBEDMENT DEPTH IS INTO DECK, AND DOES NOT COUNT SIP FLUTES. IF ADDITIONAL LENGTH IS REQUIRED, AN M12 MAY BE SUBSTITUTED IN PLACE OF M10.

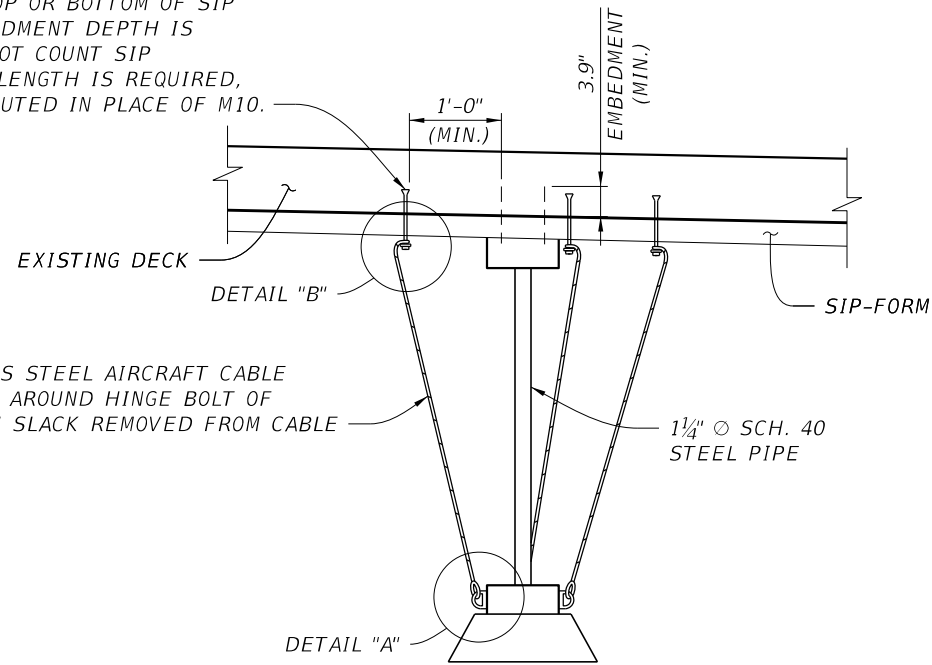

3/32" 7x19 STAINLESS STEEL AIRCRAFT CABLE SHALL BE ANCHORED AROUND HINGE BOLT OF LIGHT HOUSING WITH SLACK REMOVED FROM CABLE

1 1/4" Ø SCH. 40 STEEL PIPE

**REDUNDANT LUMINAIRE SUPPORT DETAIL**  
(EXISTING BRIDGE DECK)  
(DECK REINFORCING AND GIRDER NOT SHOWN FOR CLARITY)

ASTM A563 GRADE DH HEAVY-HEX SELF LOCKING NUT  
4" SQUARE BY 3/8" THICK ASTM A36 PLATE WASHER  
1/2" DIA. BOLT ASTM F3125, GRADE A325, TYPE I  
3 1/2" EMBEDMENT (MIN.) BOTTOM OF WASHER SHALL ABOVE TOP OF BOTTOM DECK STEEL MAT  
BOTTOM MAT OF DECK REINFORCING

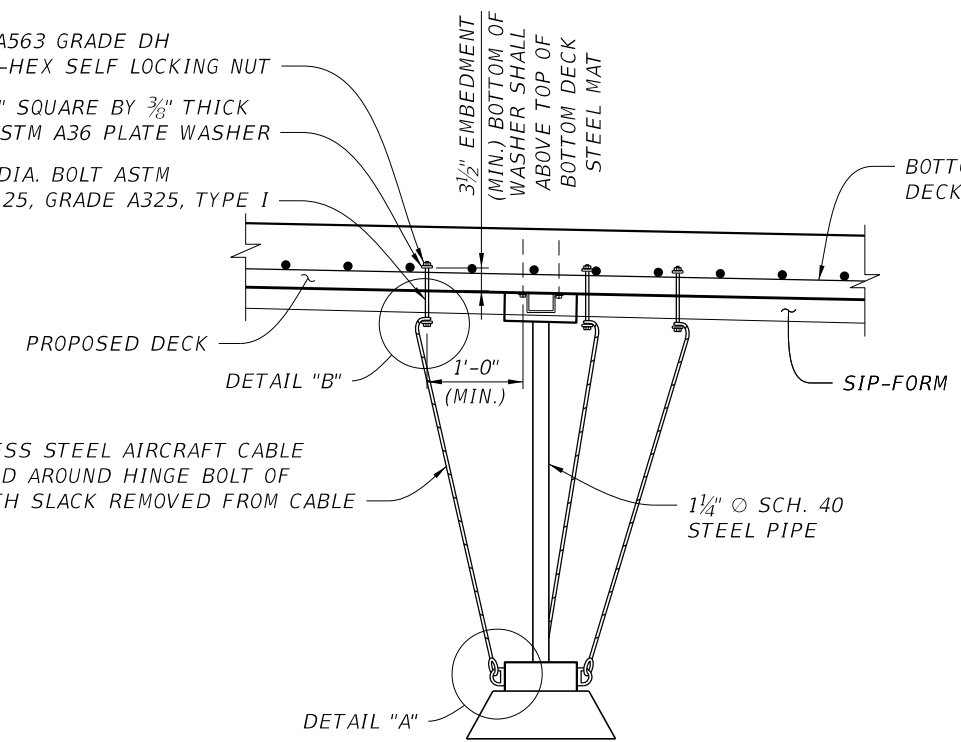

3/32" 7x19 STAINLESS STEEL AIRCRAFT CABLE SHALL BE ANCHORED AROUND HINGE BOLT OF LIGHT HOUSING WITH SLACK REMOVED FROM CABLE

1 1/4" Ø SCH. 40 STEEL PIPE

**REDUNDANT LUMINAIRE SUPPORT DETAIL**  
(PROPOSED BRIDGE DECK)  
(TOP OF DECK REINFORCING AND GIRDER NOT SHOWN FOR CLARITY)

**EXISTING DECK NOTES**

1. CONTRACTOR SHALL EXERCISE CAUTION WHEN DRILLING TO NOT DAMAGE EXISTING DECK REINFORCEMENT. IF REINFORCING STEEL IS ENCOUNTERED, STOP DRILLING AND DRILL IN ANOTHER LOCATION. THE UNUSED HOLE SHALL BE FILLED WITH APPROVED NON-SHRINK GROUT AND EPOXY CONFORMING TO SPECIFICATIONS 926 AND 934.
  - A. THOROUGHLY CLEAN AREA OF CONCRETE REMOVING ALL DEBRIS BEFORE APPLYING EPOXY AND GROUT MATERIAL.
  - B. COAT CONCRETE AREA WITH APPROVED EPOXY COMPOUND, APPLIED IN ACCORDANCE WITH MANUFACTURER'S RECOMMENDATIONS, AND THEN FILL WITH APPROVED HIGH-STRENGTH, NON-SHRINK GROUT APPLIED IN ACCORDANCE WITH MANUFACTURER'S RECOMMENDATIONS.
  - C. FIRMLY CONSOLIDATE GROUT AND RESTORE TO ORIGINAL SHAPE.

**GENERAL NOTES**

1. PRIOR TO MATERIAL ORDER, THE CONTRACTOR SHALL SUBMIT FOR APPROVAL MATERIAL SPECIFICATIONS AND DESIGN DATA FOR ALL MATERIALS PROPOSED FOR THE PROJECT. THESE MUST INCLUDE:
  - A. LUMINAIRE MANUFACTURER AND CUT SHEET.
  - B. ELECTRICAL MATERIAL INCLUDING JUNCTION BOX AND PENDANT BRACKET. JUNCTION BOX AND PENDANT BRACKET SHALL BE ABLE TO SUPPORT ENTIRE PENDANT HUNG LUMINAIRE ASSEMBLY.
2. CONTRACTOR SHALL ENSURE THAT STAINLESS STEEL CABLE CAN NOT SLIP OFF UNDERCUT ANCHOR OR A325 BOLT. IF NEEDED, A 1/2" THICK STAINLESS STEEL WASHER WITH ROUNDED EDGES SHALL BE INSTALLED BELOW STAINLESS STEEL CABLE IF THE HEAD OF UNDERCUT ANCHOR OR A325 BOLT IS NOT LARGE ENOUGH TO PREVENT SLIPPING. WASHER SHALL HAVE  $f_y=36$  KSI OR GREATER.
3. DESIGN ASSUMPTIONS AND LIMITATIONS. FOR PROJECTS WHERE ANY OF THESE ASSUMPTIONS ARE NOT MET, PROJECT SPECIFIC DESIGN SHALL BE REQUIRED, AND SIGNED AND SEALED BY A PROFESSIONAL ENGINEER REGISTERED IN THE STATE OF FLORIDA.
  - A. LUMINAIRES SHALL HAVE A MAXIMUM WEIGHT OF 75 POUNDS.
  - B. VERTICAL DISTANCE BETWEEN TOP OF BRIDGE DECK AND BOTTOM OF GIRDER SHALL NOT EXCEED 14'.
  - C. BRIDGE DECK SHALL HAVE A MINIMUM 28-DAY COMPRESSIVE STRENGTH OF 3000 PSI.
  - D. BRIDGE DECK SHALL HAVE A MINIMUM THICKNESS OF 6 1/2".

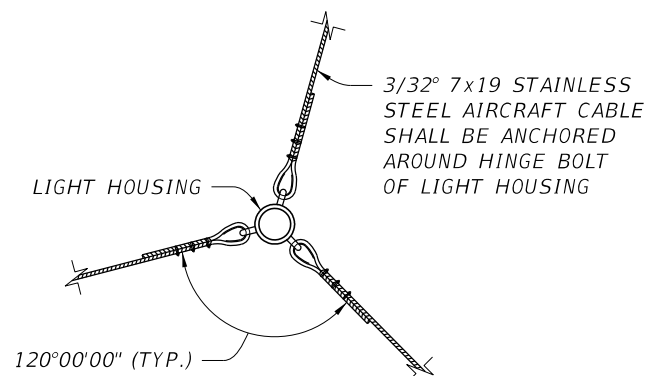

**PLAN VIEW**

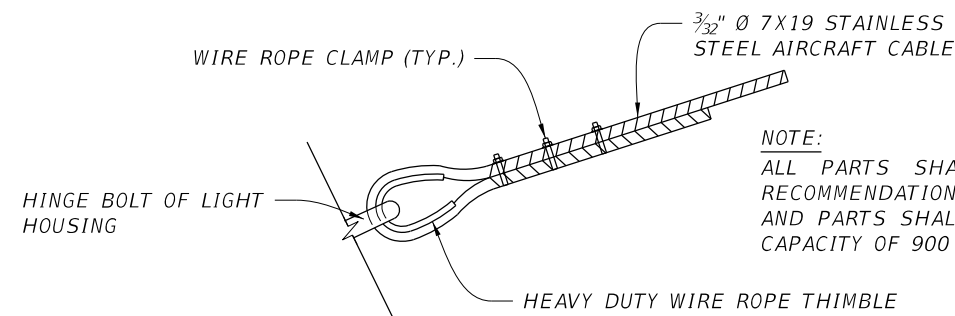

**DETAIL "A"**

NOTE:  
ALL PARTS SHALL BE PER MANUFACTURER'S RECOMMENDATIONS. ALL CABLES, CONNECTIONS AND PARTS SHALL HAVE A MINIMUM WORKING CAPACITY OF 900 LBS.

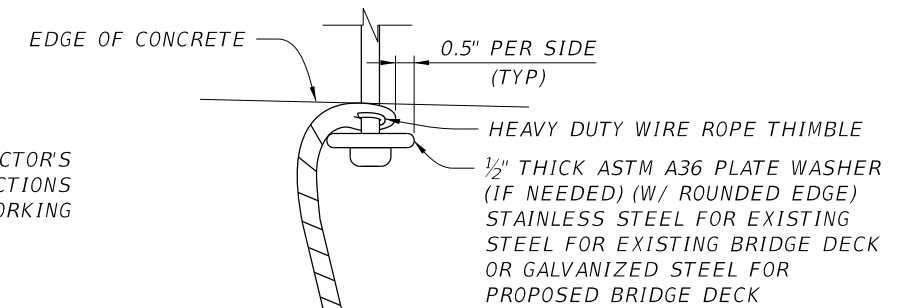

**DETAIL "B"**

REVISIONS				ENGINEER OF RECORD FULL NAME, P.E. P.E. LICENSE NUMBER 99999 ENGINEER OF RECORD COMPANY NAME ENGINEER OF RECORD COMPANY STREET ENGINEER OF RECORD CITY, STATE AND ZIP	PROJECT NAME (1 to 3 LINES)		CENTRAL FLORIDA EXPRESSWAY AUTHORITY	REDUNDANT LUMINAIRE SUPPORT DETAIL	SHEET NO.  F-5
DATE	DESCRIPTION	DATE	DESCRIPTION		ROAD NO.	PROJECT NO.			

THE OFFICIAL RECORD OF THIS SHEET IS THE ELECTRONIC FILE DIGITALLY SIGNED AND SEALED UNDER RULE 61G15-23.004, F.A.C.

W:\50088189\CFX Design Guidelines\CADD and Details\Lighting - Progress Working Files\G - Remote LED Driver Cabinet Details\LT\_601.dgn 3:04:32 PM 3/7/2025 ggrant@ham

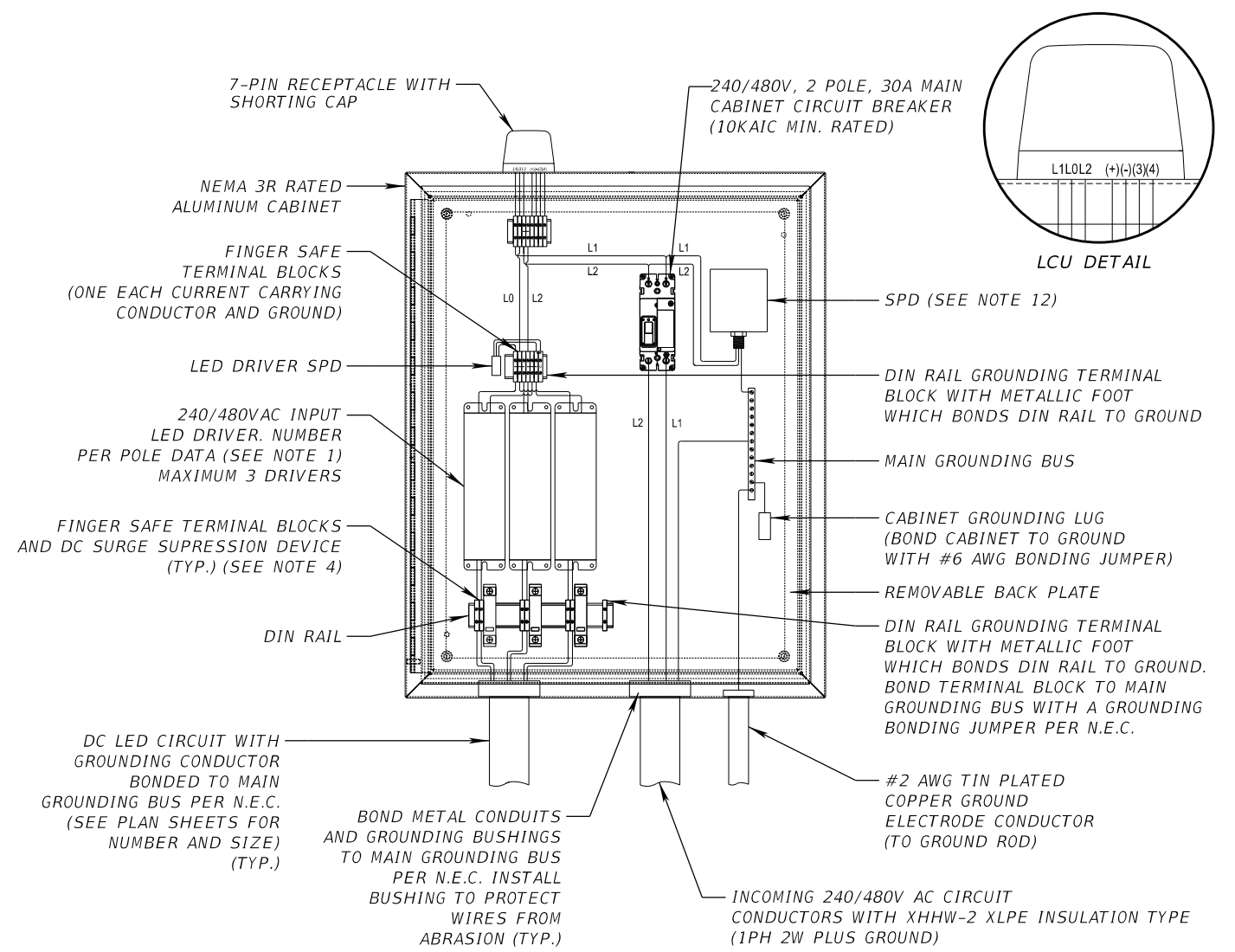
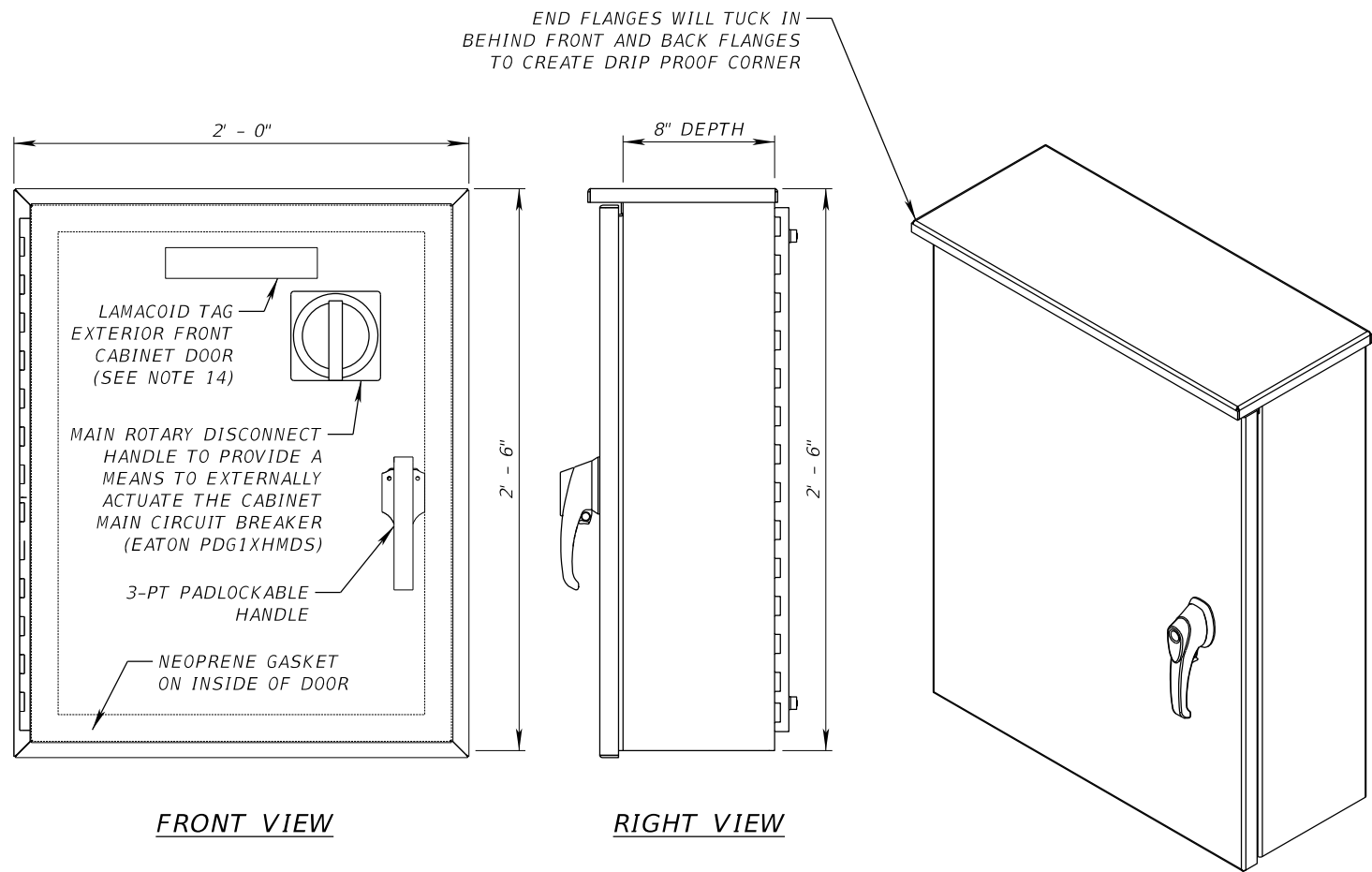

**NOTES:**

1. LED DRIVERS SHALL BE IP65, OR BETTER, RATED AND INCLUDE BUILT-IN OVERVOLTAGE, OVERCURRENT, AND SHORT CIRCUIT PROTECTIONS. DRIVERS SHALL BE RATED FOR LUMINAIRE CONNECTED LOAD PER MANUFACTURER'S RECOMMENDATION.
2. WIRING FOR THREE LED DRIVERS ARE BEING DEPICTED IN THE CABINET DETAIL FOR THE WORSE CASE SCENARIO USING MAXIMUM OF THREE LED DRIVERS PER A SINGLE LCU. EACH LED DRIVER IS USED FOR A SINGLE SIGN LIGHTING FIXTURE AND FOR A SINGLE OR ADDITIONAL UNDERDECK LIGHTING FIXTURES IN CASE OF USING PENDANT HUNG FIXTURE INSTALLATIONS. THE CABINET WIRING DETAIL SHALL BE MODIFIED FOR CORRECT NUMBER OF FIXTURES USED AT EACH SPECIFIC PROJECT SITE. IF LCUs ARE NOT USED, THEN SHORTING CAPS WILL BE PROVIDED.
3. INTERNAL WIRING OF CABINET SHALL BE XHHW-2 (XLPE) INSULATION TYPE.
4. ENSURE THAT DC SPD PROTECTING THE SECONDARY SIDE OF THE LED DRIVERS ARE SELECTED BASED UPON THE MAXIMUM OUTPUT VOLTAGE OF THE LED DRIVERS (CONSTANT CURRENT TYPE). GROUND THE SPD'S TO CABINET GROUND EITHER THROUGH THE DIN RAIL OR WITH A GROUNDING BONDING JUMPER BONDED TO THE MAIN GROUNDING BUS (PER SPD MODEL MANUFACTURER REQUIREMENTS).
5. MANUFACTURED TO NEMA 3R SPECIFICATIONS, POLE MOUNT INSTALLATION, (2) BANDING STYLE BRACKETS.
6. DOOR HINGE SHALL BE MADE OF ALUMINUM. ENSURE DOOR OPENING IS DOUBLE FLANGED ON ALL FOUR SIDES, AND THAT THE DOOR INCLUDES A CLOSED-CELL, NEOPRENE GASKET SEAL THAT IS PERMANENTLY BONDED TO THE INSIDE SUCH THAT THE NEOPRENE FORMS A WEATHER-TIGHT SEAL WHEN DOOR IS CLOSED.
7. CABINET SHELL SHALL BE CONSTRUCTED USING UNPAINTED SHEET ALUMINUM ALLOY 5052-H32 WITH A MINIMUM THICKNESS OF 0.125 INCH.
8. ENSURE GROUND BUS BARS ARE FABRICATED FROM A COPPER ALLOY MATERIAL COMPATIBLE WITH COPPER WIRE. USE GROUND BUS BARS THAT HAVE AT LEAST TWO POSITIONS WHERE A #2 AWG STRANDED COPPER WIRE CAN BE ATTACHED.
9. ALL CONDUITS SHALL BE INSTALLED FROM BOTTOM OF CABINET AND SHALL BE SEALED.
10. CONTRACTOR TO SUBMIT A CABINET WIRING AND LAYOUT DIAGRAM FOR CFX APPROVAL PRIOR TO PROCUREMENT.
11. LED REMOTE DRIVER CABINETS ARE USED FOR BOTH SIGN AND UNDERDECK LIGHTING APPLICATIONS. IN CASE OF SIGN LIGHTING, THE CABINETS SHALL BE MOUNTED ON THE UPRIGHT OF THE SIGN STRUCTURE AND POSITIONED FACING OPPOSITE OF TRAFFIC OR ON THE BACK OF THE SIGN STRUCTURE, IF THE SLOPE IS NOT TOO STEEP. THE CABINET LOCATIONS NEED TO BE COORDINATED WITH CFX TO BE SURE NO CONFLICTS EXIST.
12. SURGE PROTECTION DEVICE (SPD), TYPE 2, UL LISTED (LATEST EDITION), PER THE LATEST APPLICABLE ANSI/IEEE STANDARDS, LED STATUS LIGHT, CONNECTION USING NO.10 AWG TO LOADSIDE OF 30A BREAKER.
13. DC OUTPUT CIRCUITS FROM THE REMOTE LED DRIVER CABINET TO THE END OF THE OUTPUT FURTHEST CIRCUIT FOR SIGN AND UNDERDECK LUMINAIRES SHALL NOT EXCEED 350 FEET. IF THIS TRANSMISSION DISTANCE IS EXCEEDED, AN ADDITIONAL REMOTE LED DRIVER CABINET SHALL BE PROVIDED FOR SIGN AND/OR UNDERDECK LUMINAIRES.
14. PROVIDE ACRYLIC LAMACOID TAG ON OUTSIDE OF CABINET DOOR. SPECIFICS AND LABELING CONVENTION SHALL BE AS FOLLOWS:
  - A. COLOR: WHITE LETTERS ON BLACK.
  - B. DIMENSIONS: 5"W X 3"H.
  - C. MOUNTING TYPE: ADHESIVE BACKING.
  - D. MESSAGE:
    1. 1ST LINE (VOLTAGE)
    2. 2ND LINE (SIGN LIGHTING/UNDERDECK LIGHTING)
    3. 3RD LINE (ROADWAY) (DIRECTION) (MP XX.X)

(VOLTAGE)  
(SIGN LIGHTING/UNDERDECK LIGHTING)  
(ROADWAY) (DIRECTION) (MP XX.X)

NOT TO SCALE

REVISIONS				ENGINEER OF RECORD FULL NAME, P.E. P.E. LICENSE NUMBER 99999 ENGINEER OF RECORD COMPANY NAME ENGINEER OF RECORD COMPANY STREET ENGINEER OF RECORD CITY, STATE AND ZIP	PROJECT NAME (1 to 3 LINES)		<b>CENTRAL FLORIDA EXPRESSWAY AUTHORITY</b>	<i>SMALL SIZE REMOTE LED DRIVER CABINET DETAILS</i>	SHEET NO.
DATE	DESCRIPTION	DATE	DESCRIPTION		ROAD NO.	PROJECT NO.			G-1

THE OFFICIAL RECORD OF THIS SHEET IS THE ELECTRONIC FILE DIGITALLY SIGNED AND SEALED UNDER RULE 61G15-23.004, F.A.C.

3/7/2025 3:04:32 PM W:\50088189\CFX Design Guidelines\CADD and Details\Lighting - Progress Working Files\G - Remote LED Driver Cabinet Details\LT\_602.dgn ggrantham

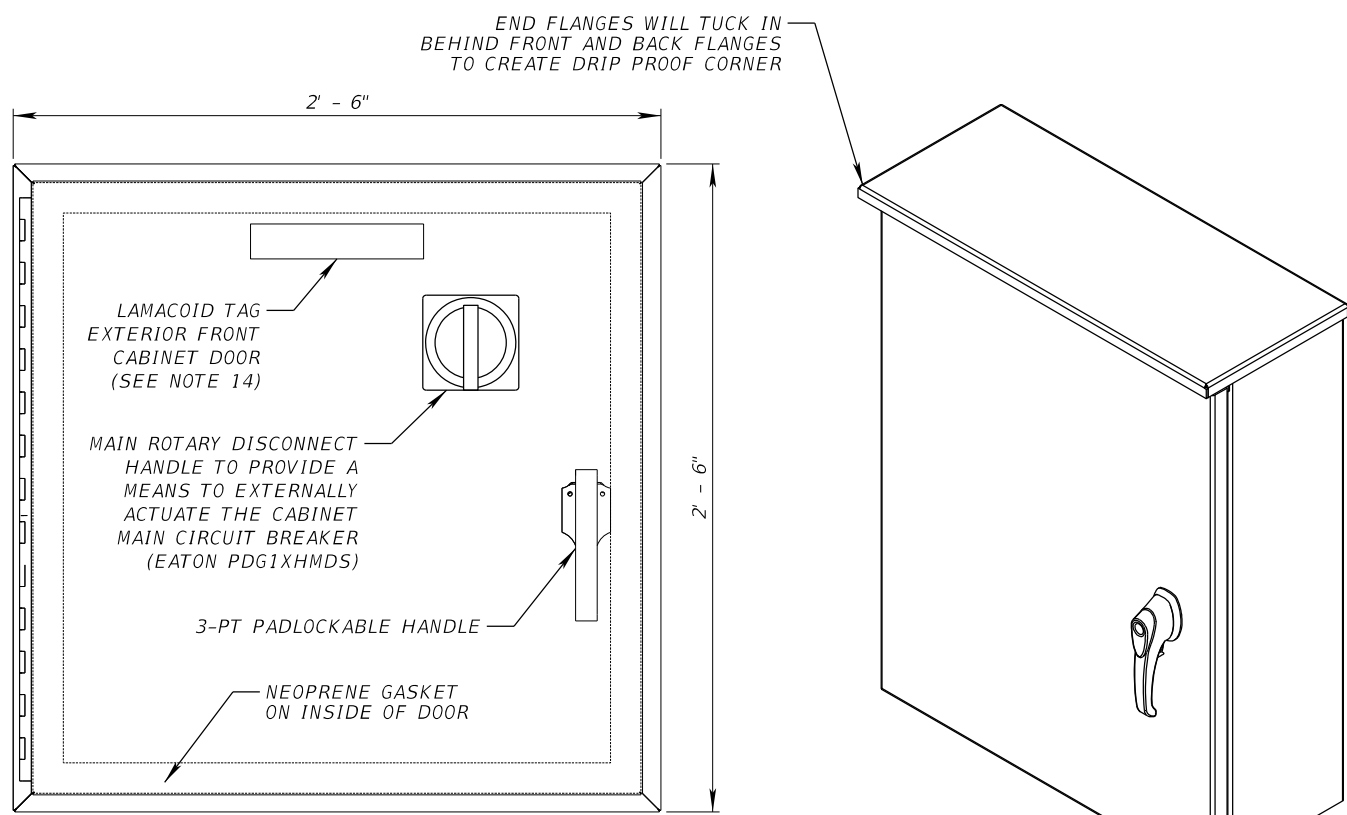

**FRONT VIEW**

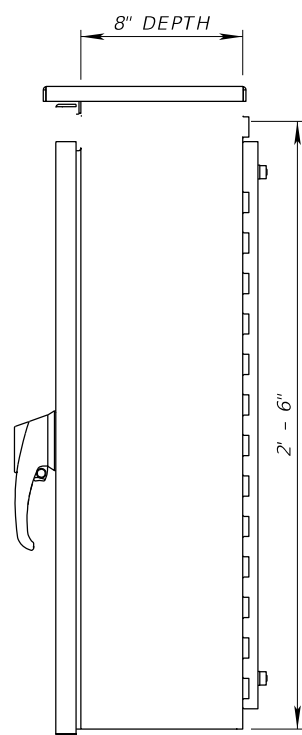
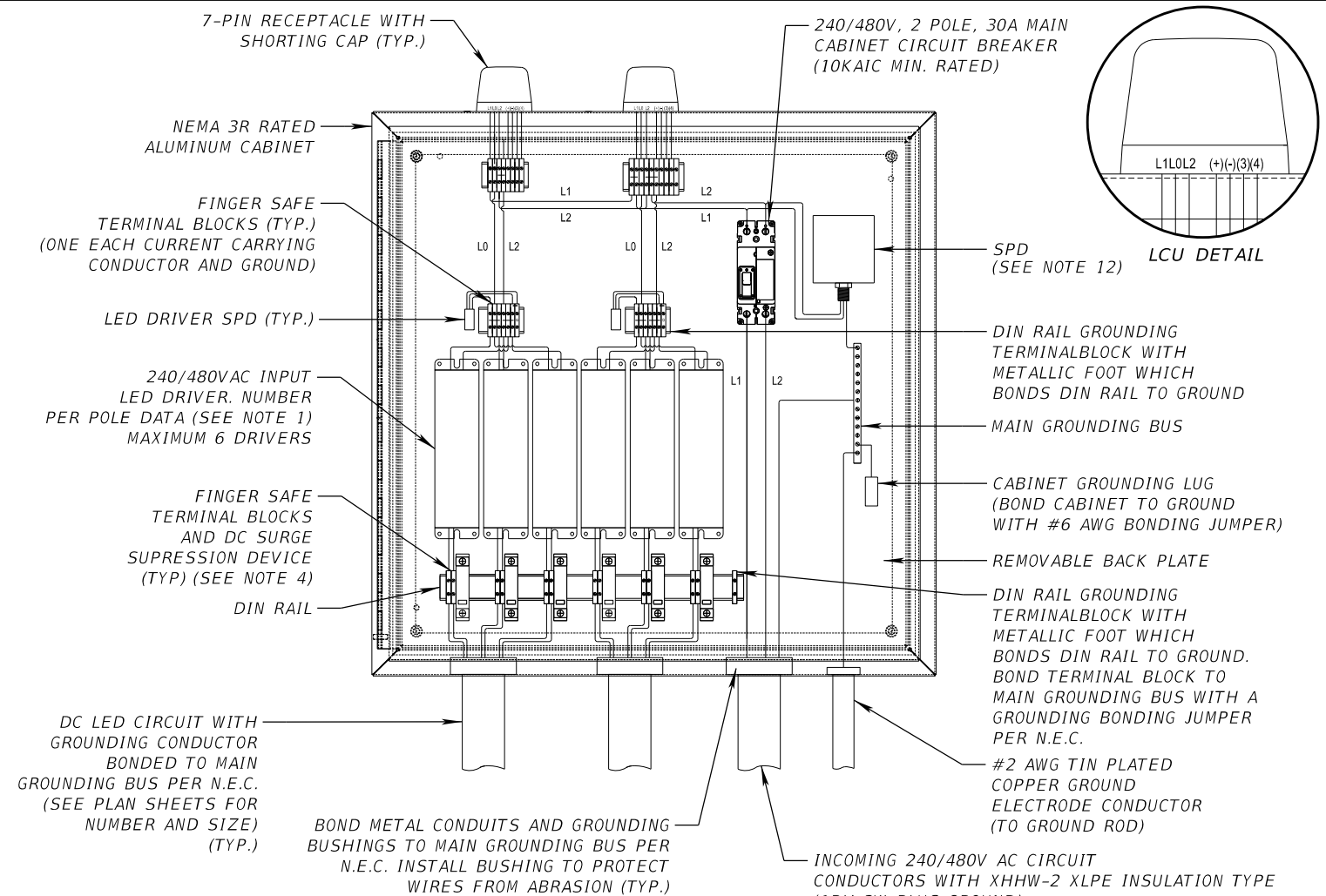

**RIGHT VIEW**

**NOTES:**

- LED DRIVERS SHALL BE IP65, OR BETTER, RATED AND INCLUDE BUILT-IN OVERVOLTAGE, OVERCURRENT, AND SHORT CIRCUIT PROTECTIONS. DRIVERS SHALL BE RATED FOR LUMINAIRE CONNECTED LOAD PER MANUFACTURER'S RECOMMENDATION.
- WIRING FOR THREE LED DRIVERS ARE BEING DEPICTED IN THE CABINET DETAIL FOR THE WORSE CASE SCENARIO USING MAXIMUM OF THREE LED DRIVERS PER A SINGLE LCU. EACH LED DRIVER IS USED FOR A SINGLE SIGN LIGHTING FIXTURE AND FOR A SINGLE OR ADDITIONAL UNDERDECK LIGHTING FIXTURES IN CASE OF USING PENDANT HUNG FIXTURE INSTALLATIONS. THE CABINET WIRING DETAIL SHALL BE MODIFIED FOR CORRECT NUMBER OF FIXTURES USED AT EACH SPECIFIC PROJECT SITE. IF LCUS ARE NOT USED, THEN SHORTING CAPS WILL BE PROVIDED.
- INTERNAL WIRING OF CABINET SHALL BE XHHW-2 (XLPE) INSULATION TYPE.
- ENSURE THAT DC SPD PROTECTING THE SECONDARY SIDE OF THE LED DRIVERS ARE SELECTED BASED UPON THE MAXIMUM OUTPUT VOLTAGE OF THE LED DRIVERS (CONSTANT CURRENT TYPE). GROUND THE SPD'S TO CABINET GROUND EITHER THROUGH THE DIN RAIL OR WITH A GROUNDING BONDING JUMPER BONDED TO THE MAIN GROUNDING BUS (PER SPD MODEL MANUFACTURER REQUIRMENTS).
- MANUFACTURED TO NEMA 3R SPECIFICATIONS, POLE MOUNT INSTALLATION, (2) BANDING STYLE BRACKETS.
- DOOR HINGE SHALL BE MADE OF ALUMINUM. ENSURE DOOR OPENING IS DOUBLE FLANGED ON ALL FOUR SIDES, AND THAT THE DOOR INCLUDES A CLOSED-CELL, NEOPRENE GASKET SEAL THAT IS PERMANENTLY BONDED TO THE INSIDE SUCH THAT THE NEOPRENE FORMS A WEATHER-TIGHT SEAL WHEN DOOR IS CLOSED.

- CABINET SHELL SHALL BE CONSTRUCTED USING UNPAINTED SHEET ALUMINUM ALLOY 5052-H32 WITH A MINIMUM THICKNESS OF 0.125 INCH.
- ENSURE GROUND BUS BARS ARE FABRICATED FROM A COPPER ALLOY MATERIAL COMPATIBLE WITH COPPER WIRE. USE GROUND BUS BARS THAT HAVE AT LEAST TWO POSITIONS WHERE A #2 AWG STRANDED COPPER WIRE CAN BE ATTACHED.
- ALL CONDUITS SHALL BE INSTALLED FROM BOTTOM OF CABINET AND SHALL BE SEALED.
- CONTRACTOR TO SUBMIT A CABINET WIRING AND LAYOUT DIAGRAM FOR CFX APPROVAL PRIOR TO PROCUREMENT.
- LED REMOTE DRIVER CABINETS ARE USED FOR BOTH SIGN AND UNDERDECK LIGHTING APPLICATIONS. IN CASE OF SIGN LIGHTING, THE CABINETS SHALL BE MOUNTED ON THE UPRIGHT OF THE SIGN STRUCTURE AND POSITIONED FACING OPPOSITE OF TRAFFIC OR ON THE BACK OF THE SIGN STRUCTURE, IF THE SLOPE IS NOT TOO STEEP. THE CABINET LOCATIONS NEED TO BE COORDINATED WITH CFX TO BE SURE NO CONFLICTS EXIST.
- SURGE PROTECTION DEVICE (SPD), TYPE 2, UL LISTED (LATEST EDITION), PER THE LATEST APPLICABLE ANSI/IEEE STANDARDS, LED STATUS LIGHT, CONNECTION USING NO.10 AWG TO LOADSIDE OF 30A BREAKER.
- DC OUTPUT CIRCUITS FROM THE REMOTE LED DRIVER CABINET TO THE END OF THE OUTPUT FURTHEST CIRCUIT FOR SIGN AND UNDERDECK LUMINAIRES SHALL NOT EXCEED 350 FEET. IF THIS TRANSMISSION DISTANCE IS EXCEEDED, AN ADDITIONAL REMOTE LED DRIVER CABINET SHALL BE PROVIDED FOR SIGN AND/OR UNDERDECK LUMINAIRES.
- PROVIDE ACRYLIC LAMACOID TAG ON OUTSIDE OF CABINET DOOR. SPECIFICS AND LABELING CONVENTION SHALL BE AS FOLLOWS:
  - A. COLOR: WHITE LETTERS ON BLACK.
  - B. DIMENSIONS: 5"W X 3"H.
  - C. MOUNTING TYPE: ADHESIVE BACKING.
  - D. MESSAGE:
    - 1. 1ST LINE (VOLTAGE)
    - 2. 2ND LINE (SIGN LIGHTING/UNDERDECK LIGHTING)
    - 3. 3RD LINE (ROADWAY) (DIRECTION) (MP XX.X)

(VOLTAGE)  
(SIGN LIGHTING/UNDERDECK LIGHTING)  
(ROADWAY) (DIRECTION) (MP XX.X)

NOT TO SCALE

REVISIONS				ENGINEER OF RECORD FULL NAME, P.E. P.E. LICENSE NUMBER 99999 ENGINEER OF RECORD COMPANY NAME ENGINEER OF RECORD COMPANY STREET ENGINEER OF RECORD CITY, STATE AND ZIP	PROJECT NAME (1 to 3 LINES)	CENTRAL FLORIDA EXPRESSWAY AUTHORITY	MEDIUM SIZE REMOTE LED DRIVER CABINET DETAILS	SHEET NO.  G-2
DATE	DESCRIPTION	DATE	DESCRIPTION					

THE OFFICIAL RECORD OF THIS SHEET IS THE ELECTRONIC FILE DIGITALLY SIGNED AND SEALED UNDER RULE 61G15-23.004, F.A.C.

W:\50088189\CFX Design Guidelines\CADD and Details\Lighting -Progress Working Files\G - Remote LED Driver Cabinet Details\LT\_603.dgn 3:04:33 PM 3/7/2025 ggrant@ham

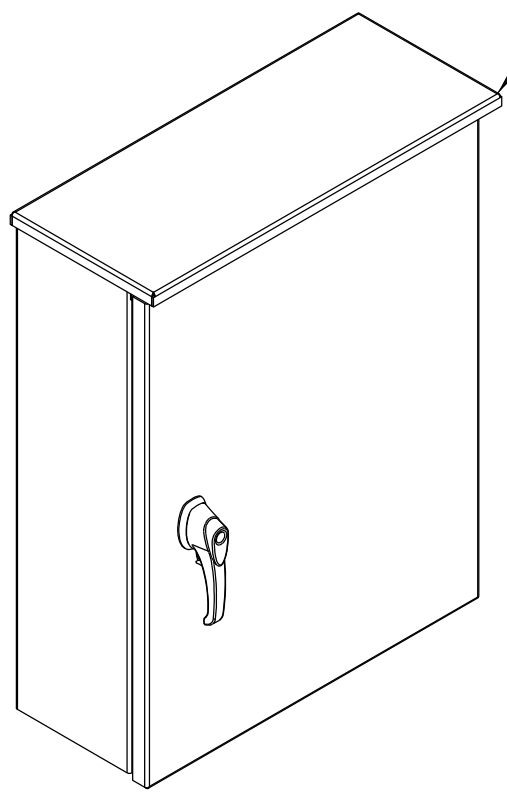
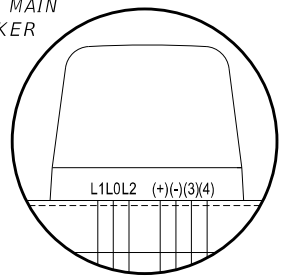
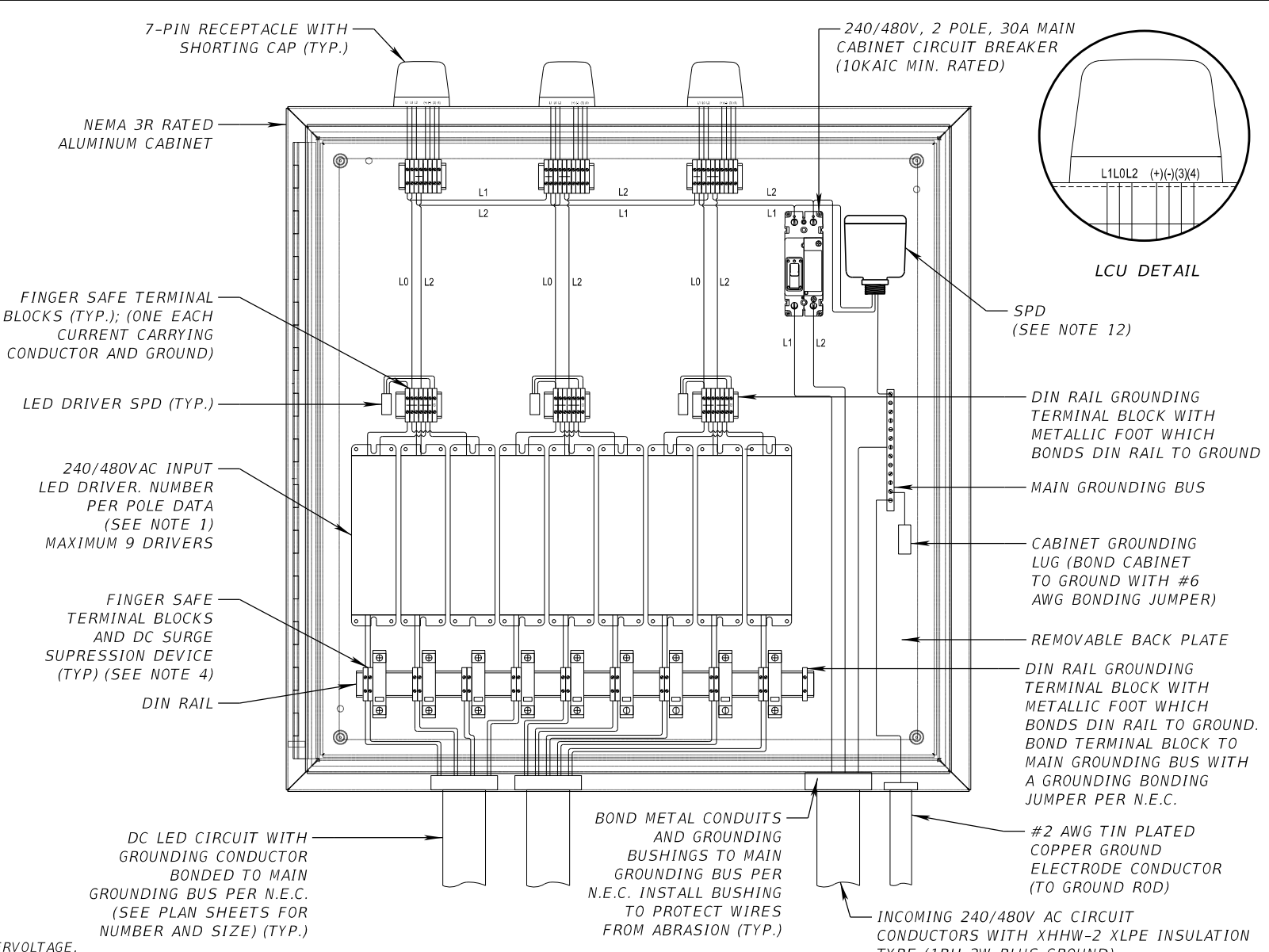
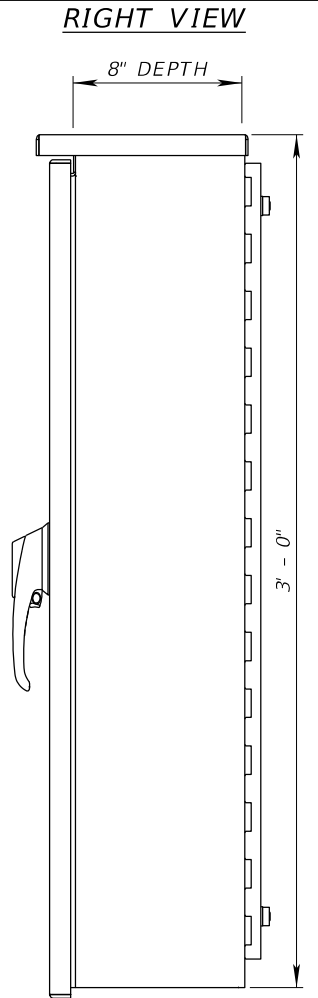
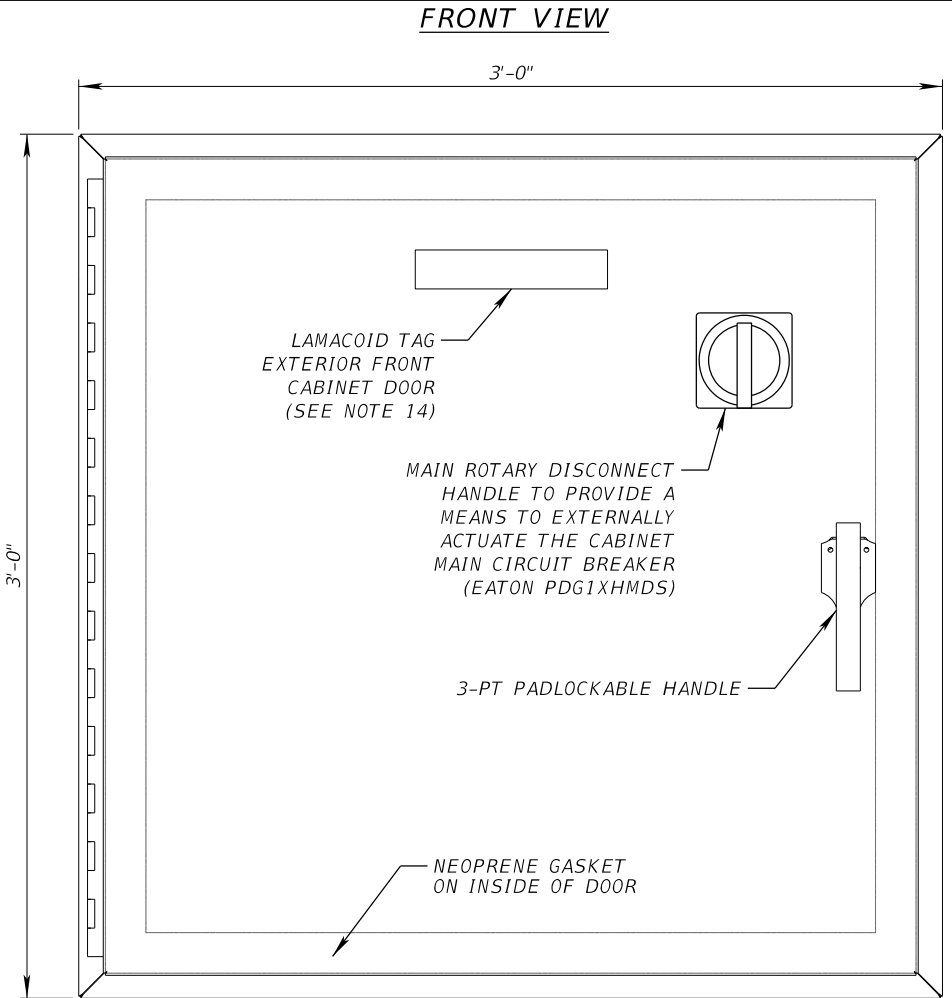

END FLANGES WILL TUCK IN BEHIND FRONT AND BACK FLANGES TO CREATE DRIP PROOF CORNER

**NOTES:**

- LED DRIVERS SHALL BE IP65, OR BETTER, RATED AND INCLUDE BUILT-IN OVERVOLTAGE, OVERCURRENT, AND SHORT CIRCUIT PROTECTIONS. DRIVERS SHALL BE RATED FOR LUMINAIRE CONNECTED LOAD PER MANUFACTURER'S RECOMMENDATION.
- WIRING FOR THREE LED DRIVERS ARE BEING DEPICTED IN THE CABINET DETAIL FOR THE WORSE CASE SCENARIO USING MAXIMUM OF THREE LED DRIVERS PER A SINGLE LCU. EACH LED DRIVER IS USED FOR A SINGLE SIGN LIGHTING FIXTURE AND FOR A SINGLE OR ADDITIONAL UNDERDECK LIGHTING FIXTURES IN CASE OF USING PENDANT HUNG FIXTURE INSTALLATIONS. THE CABINET WIRING DETAIL SHALL BE MODIFIED FOR CORRECT NUMBER OF FIXTURES USED AT EACH SPECIFIC PROJECT SITE. IF LCUS ARE NOT USED, THEN SHORTING CAPS WILL BE PROVIDED.
- INTERNAL WIRING OF CABINET SHALL BE XHHW-2 (XLPE) INSULATION TYPE.
- ENSURE THAT DC SPD PROTECTING THE SECONDARY SIDE OF THE LED DRIVERS ARE SELECTED BASED UPON THE MAXIMUM OUTPUT VOLTAGE OF THE LED DRIVERS (CONSTANT CURRENT TYPE). GROUND THE SPD'S TO CABINET GROUND EITHER THROUGH THE DIN RAIL OR WITH A GROUNDING BONDING JUMPER BONDED TO THE MAIN GROUNDING BUS (PER SPD MODEL MANUFACTURER REQUIREMENTS).
- MANUFACTURED TO NEMA 3R SPECIFICATIONS, POLE MOUNT INSTALLATION, (2) BANDING STYLE BRACKETS.
- DOOR HINGE SHALL BE MADE OF ALUMINUM. ENSURE DOOR OPENING IS DOUBLE FLANGED ON ALL FOUR SIDES, AND THAT THE DOOR INCLUDES A CLOSED-CELL, NEOPRENE GASKET SEAL THAT IS PERMANENTLY BONDED TO THE INSIDE SUCH THAT THE NEOPRENE FORMS A WEATHER-TIGHT SEAL WHEN DOOR IS CLOSED.
- CABINET SHELL SHALL BE CONSTRUCTED USING UNPAINTED SHEET ALUMINUM ALLOY 5052-H32 WITH A MINIMUM THICKNESS OF 0.125 INCH.

- ENSURE GROUND BUS BARS ARE FABRICATED FROM A COPPER ALLOY MATERIAL COMPATIBLE WITH COPPER WIRE. USE GROUND BUS BARS THAT HAVE AT LEAST TWO POSITIONS WHERE A #2 AWG STRANDED COPPER WIRE CAN BE ATTACHED.
- ALL CONDUITS SHALL BE INSTALLED FROM BOTTOM OF CABINET AND SHALL BE SEALED.
- CONTRACTOR TO SUBMIT A CABINET WIRING AND LAYOUT DIAGRAM FOR CFX APPROVAL PRIOR TO PROCUREMENT.
- LED REMOTE DRIVER CABINETS ARE USED FOR BOTH SIGN AND UNDERDECK LIGHTING APPLICATIONS. IN CASE OF SIGN LIGHTING, THE CABINETS SHALL BE MOUNTED ON THE UPRIGHT OF THE SIGN STRUCTURE AND POSITIONED FACING OPPOSITE OF TRAFFIC OR ON THE BACK OF THE SIGN STRUCTURE, IF THE SLOPE IS NOT TOO STEEP. THE CABINET LOCATIONS NEED TO BE COORDINATED WITH CFX TO BE SURE NO CONFLICTS EXIST.
- SURGE PROTECTION DEVICE (SPD), TYPE 2, UL LISTED (LATEST EDITION), PER THE LATEST APPLICABLE ANSI/IEEE STANDARDS, LED STATUS LIGHT, CONNECTION USING NO.10 AWG TO LOADSIDE OF 30A BREAKER.
- DC OUTPUT CIRCUITS FROM THE REMOTE LED DRIVER CABINET TO THE END OF THE OUTPUT FURTHEST CIRCUIT FOR SIGN AND UNDERDECK LUMINAIRES SHALL NOT EXCEED 350 FEET. IF THIS TRANSMISSION DISTANCE IS EXCEEDED, AN ADDITIONAL REMOTE LED DRIVER CABINET SHALL BE PROVIDED FOR SIGN AND/OR UNDERDECK LUMINAIRES.
- PROVIDE ACRYLIC LAMACOID TAG ON OUTSIDE OF CABINET DOOR. SPECIFICS AND LABELING CONVENTION SHALL BE AS FOLLOWS:
  - COLOR: WHITE LETTERS ON BLACK.
  - DIMENSIONS: 5"W X 3"H.
  - MOUNTING TYPE: ADHESIVE BACKING.
  - MESSAGE:
    - 1ST LINE (VOLTAGE)
    - 2ND LINE (SIGN LIGHTING/UNDERDECK LIGHTING)
    - 3RD LINE (ROADWAY) (DIRECTION) (MP XX.X)

(VOLTAGE)  
(SIGN LIGHTING/UNDERDECK LIGHTING)  
(ROADWAY) (DIRECTION) (MP XX.X)

NOT TO SCALE

REVISIONS			
DATE	DESCRIPTION	DATE	DESCRIPTION

ENGINEER OF RECORD FULL NAME, P.E.  
P.E. LICENSE NUMBER 99999  
ENGINEER OF RECORD COMPANY NAME  
ENGINEER OF RECORD COMPANY STREET  
ENGINEER OF RECORD CITY, STATE AND ZIP

PROJECT NAME  
(1 to 3 LINES)  
ROAD NO. PROJECT NO.



**LARGE SIZE REMOTE LED DRIVER CABINET DETAILS**

SHEET NO.  
G-3

THE OFFICIAL RECORD OF THIS SHEET IS THE ELECTRONIC FILE DIGITALLY SIGNED AND SEALED UNDER RULE 61G15-23.004, F.A.C.

W:\50088189\CFX Design Guidelines\CADD and Details\Lighting - Progress Working Files\H - Remote Driver Cabinet Conduit Routing Details\VT\_H01.DGN  
 3:04:33 PM  
 3/7/2025  
 ggrant@ham

**PENDANT HUNG UNDERDECK WITH SIGN LIGHTING (TYP.)  
WIRING DETAIL**

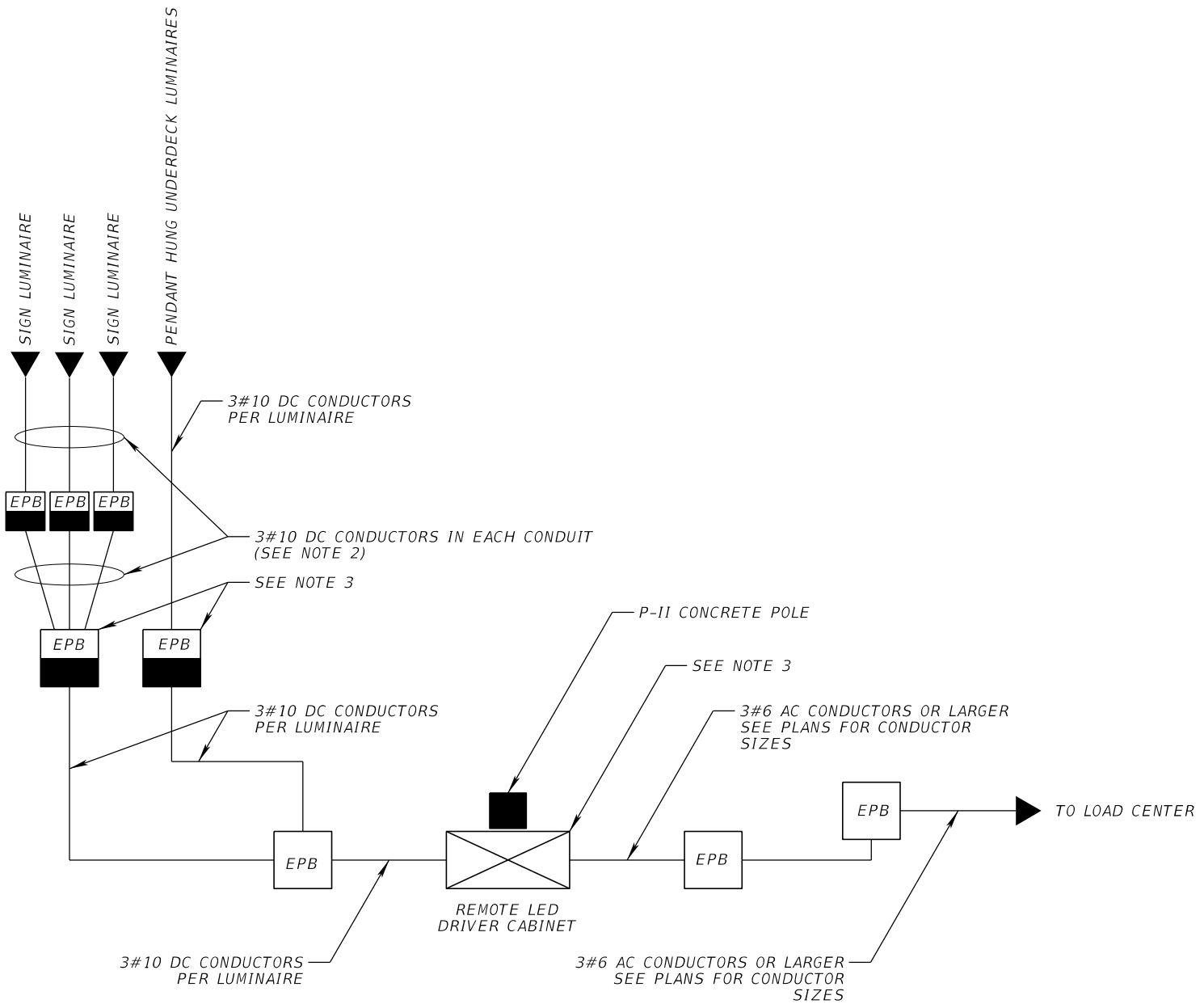

- NOTES:**
1. CONDUIT NUMBER MAY VARY ACCORDING TO NUMBER OF SIGN LUMINAIRES ON BRIDGE.
  2. NO SPLICING TOGETHER OF CONDUCTORS TO BE PERFORMED PRIOR TO ENTERING REMOTE LED DRIVER CABINET.
  3. FOR CASES WHERE SIGN LIGHTING AND PENDANT HUNG UNDERDECK LIGHTING ARE IN CLOSE PROXIMITY, ONE LARGE REMOTE LED DRIVER CABINET CAN BE USED IN LIEU OF TWO LARGE REMOTE LED DRIVER CABINETS, AS LONG AS THEY DO NOT EXCEED MORE THAN NINE LED DRIVERS. IF TEN OR MORE LED DRIVERS ARE REQUIRED, TWO SEPARATE REMOTE LED DRIVER CABINETS MUST BE USED.

**PENDANT HUNG UNDERDECK ONLY (TYP.)  
WIRING DETAIL**

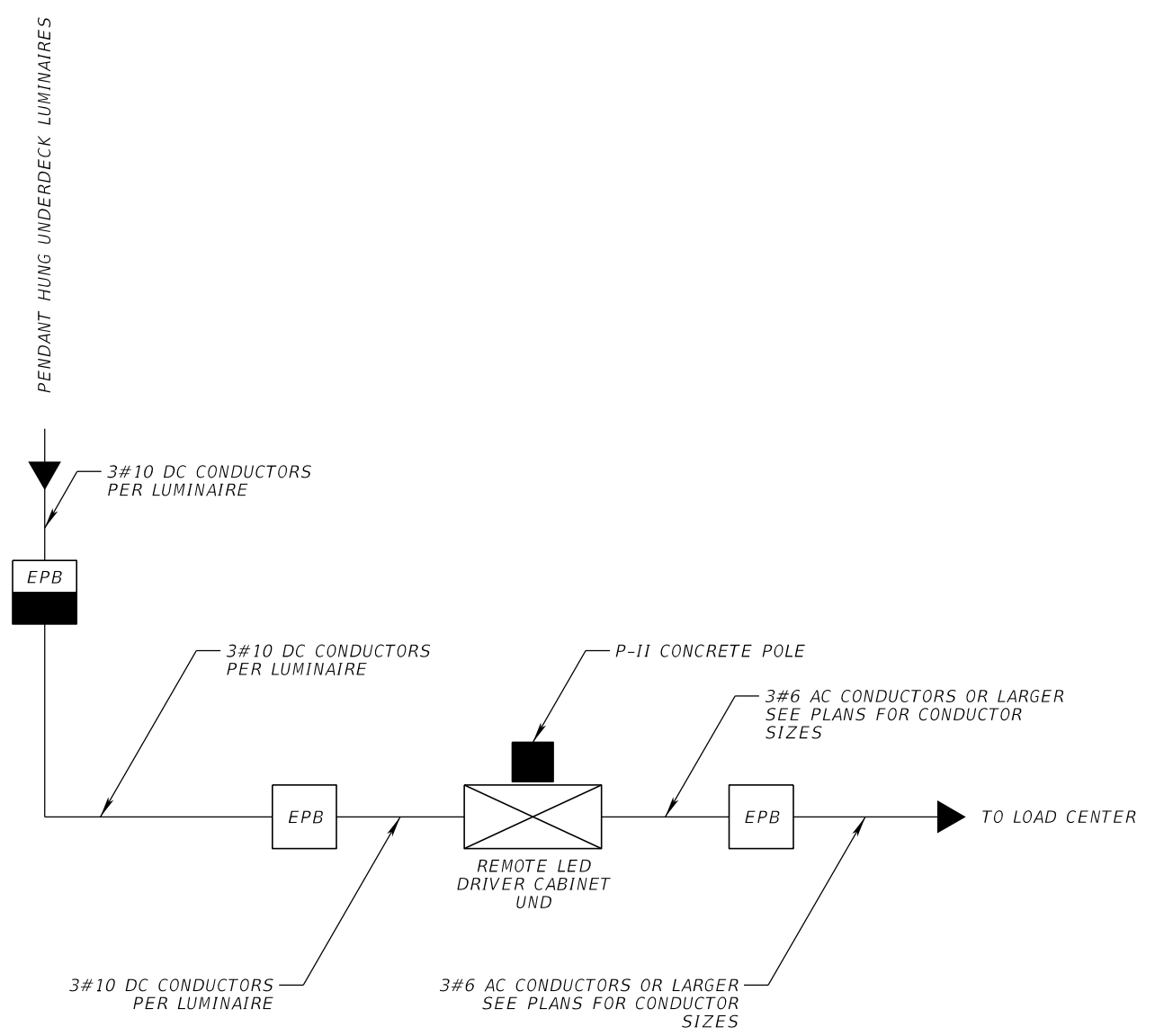

- SHOULDER MOUNTED ELECTRICAL PULL BOX
- SURFACE MOUNTED ELECTRICAL PULL BOX

REVISIONS				ENGINEER OF RECORD FULL NAME, P.E. P.E. LICENSE NUMBER 99999 ENGINEER OF RECORD COMPANY NAME ENGINEER OF RECORD COMPANY STREET ENGINEER OF RECORD CITY, STATE AND ZIP	PROJECT NAME (1 to 3 LINES)		CENTRAL FLORIDA EXPRESSWAY AUTHORITY	REMOTE LED DRIVER CABINET DETAILS	SHEET NO.
DATE	DESCRIPTION	DATE	DESCRIPTION		ROAD NO.	PROJECT NO.			H-1

THE OFFICIAL RECORD OF THIS SHEET IS THE ELECTRONIC FILE DIGITALLY SIGNED AND SEALED UNDER RULE 61G15-23.004, F.A.C.



W:\50088189\CFX Design Guidelines\CADD and Details\Lighting -Progress Working Files\J- Maintenance Lighting Details\LT\_J01.dgn  
 3:04:34 PM  
 3/7/2025  
 ggrant@ham

**BOX GIRDER MAINTENANCE LIGHTING NOTES:**

1. SUBMIT SHOP DRAWINGS TO THE ENGINEER DETAILING THE LAYOUT OF THE MAINTENANCE LIGHTING SYSTEM FOR THE ENTIRE STRUCTURE. THE SHOP DRAWINGS MUST INCLUDE, BUT NOT BE LIMITED TO, THE FOLLOWING ITEMS:
  - A. CONDUIT LAYOUT AND INSTALLATION DETAILS THROUGH DIAPHRAGMS, AROUND POST-TENSIONING (PT) DUCTS, LATERAL BRACING AND CROSS FRAMES AS NECESSARY.
  - B. CONDUIT ACCESS THROUGH BOX GIRDER END DIAPHRAGMS WITH MINIMUM 1" CLEARANCE IN ALL DIRECTIONS.
  - C. CONDUIT EXPANSION FITTING DETAILS.
  - D. FASTENER DETAILS FOR THE INTERIOR ELECTRICAL SYSTEM.
  - E. SINGLE LINE DIAGRAM SHOWING MINI POWER CENTERS, SWITCHES, CONTACTORS, TIMERS, ETC.
  - F. MINI POWER CENTER DETAILS INCLUDING CIRCUIT BREAKER DETAILS.
  - G. MINI POWER CENTER MOUNTING DETAILS IF REQUIRED.
  - H. FEEDER SCHEDULE.
2. ENSURE INSTALLATION MEETS ALL REQUIREMENTS OF THE LATEST EDITION OF THE NATIONAL ELECTRICAL CODE (NEC) AND LOCAL ORDINANCES. INSTALL GROUNDING IN ACCORDANCE WITH NEC ARTICLE 250. MAINTAIN SEPARATION BETWEEN 480V AND 120V CONDUCTORS / CONDUITS THROUGHOUT.
3. FURNISH ALL LABOR, EQUIPMENT, MATERIALS, AND INCIDENTALS REQUIRED FOR A COMPLETE AND FUNCTIONAL INSTALLATION.
4. USE ONLY NEW, UNUSED AND UNDERWRITERS LABORATORIES (UL) LISTED EQUIPMENT AND MATERIALS FOR OUTDOOR USE.
5. FURNISH AND INSTALL POLYVINYL CHLORIDE (PVC) CONDUIT IN CONFORMANCE WITH UL SECTION 651, NEC SECTION 347 AND NEMA TC-2, UV-RESISTANT AND SCHEDULE 80. BEND CONDUITS AS NECESSARY TO CONNECT TO LOADS.
6. PROVIDE PVC SLEEVE 2" LARGER IN DIAMETER THAN CONDUIT TO ACCOMMODATE CONSTRUCTION TOLERANCE.
7. INSTALL A UL LABELED EXPANSION FITTING FOR SPECIFIED PVC CONDUIT AT ALL STRUCTURE EXPANSION JOINTS. PROVIDE CERTIFICATION THAT THE EXPANSION FITTING MEETS THE FOLLOWING MINIMUM REQUIREMENTS: COMPATIBILITY WITH THE CONNECTED CONDUITS, WATERPROOF, UV PROTECTED AND ALLOWS LONGITUDINAL MOVEMENT EQUAL TO THAT OF THE EXPANSION JOINT.
8. USE ONLY ALLOY 316 STAINLESS STEEL SUPPORTING HARDWARE. PROVIDE MINIMUM 1/16" Ø FASTENERS. FOR CONCRETE OR SIP FORM MOUNTING, PROVIDE ANCHOR BOLTS (EXPANSION, DROP-IN OR ADHESIVE) SUITABLE FOR DYNAMIC LOADING (DUE TO VIBRATION CAUSED BY TRAFFIC). INSTALL FASTENERS TO AVOID CONFLICTS WITH REINFORCING STEEL AND PT DUCTS. FOR STRUCTURAL STEEL MOUNTING, DO NOT ATTACH FASTENERS TO MAIN MEMBERS, I.E. WEBS AND FLANGES.
9. FURNISH POWER DISTRIBUTION AT 480V AC, 1 PHASE, WITH STEP DOWN TRANSFORMERS AT REGULAR INTERVALS. FURNISH 7.5 KVA MINI POWER CENTER WITH EIGHT 20A BREAKERS AS THE STEP DOWN TRANSFORMER, FEEDING A MAXIMUM OF 20 LAMPS AND 20 RECEPTACLES. EACH MINI POWER CENTER WILL PROVIDE POWER TO NO MORE THAN 1000' OF BRIDGE, PREFERABLY 500' ON EACH SIDE OF THE MINI POWER CENTER. 480V TOP FEED, 120V BOTTOM FEED TO MAINTAIN SEPARATION.
10. FURNISH AND INSTALL LIGHTING CONTACTORS TO SWITCH THE 480V AC FEEDING THE MINI POWER CENTERS.
11. FURNISH AND INSTALL COPPER CONDUCTORS, TYPE XHHW. DO NOT USE ANY CONDUCTOR LARGER THAN #4 AWG.
12. PROVIDE ENOUGH SLACK IN ALL INTERIOR CABLE TERMINATIONS TO ALLOW FOR MINOR SHIFTING OF THE STRUCTURE.
13. FURNISH AND INSTALL NATIONAL ELECTRIC MANUFACTURERS ASSOCIATION (NEMA) TYPE 4X (NON-METALLIC) SURFACE MOUNTED BOXES SIZED IN CONFORMANCE WITH THE NEC.
14. FURNISH AND INSTALL 120V DUPLEX RECEPTACLES (GFI, NEMA TYPE 5-20R), IN NON-METALLIC OUTLET BOXES AT 50' MAXIMUM ON CENTERS. PROVIDE EACH RECEPTACLE WITH A GASKETED WEATHER-PROTECTIVE OUTDOOR PLATE. MAXIMUM WIRE SIZE TO CONNECT TO RECEPTACLES IS #12 AWG.
15. FURNISH AND INSTALL SURFACE MOUNTED, FULLY ENCLOSED, 14 WATT LED LIGHT FIXTURES WITH GASKETED CLEAR GLOBES AND WIRE GUARDS AT 50' MAXIMUM ON CENTERS. SIGNIFY VWCL-14-NW-G1-8 OR APPROVED EQUAL.
16. PROVIDE SIX HOUR RESET TIMERS FOR EACH CIRCUIT TO TURN OFF THE LIGHTING SYSTEM AUTOMATICALLY.

CROSS REFERENCES:

1. FOR BOX GIRDER INFORMATION, REFER TO STRUCTURES PLANS.

REVISIONS				ENGINEER OF RECORD FULL NAME, P.E. P.E. LICENSE NUMBER 99999 ENGINEER OF RECORD COMPANY NAME ENGINEER OF RECORD COMPANY STREET ENGINEER OF RECORD CITY, STATE AND ZIP	PROJECT NAME (1 to 3 LINES)			<b>MAINTENANCE LIGHTING FOR BOX GIRDERS</b>	SHEET NO.
DATE	DESCRIPTION	DATE	DESCRIPTION		ROAD NO.	PROJECT NO.			J-1

THE OFFICIAL RECORD OF THIS SHEET IS THE ELECTRONIC FILE DIGITALLY SIGNED AND SEALED UNDER RULE 61G15-23.004, F.A.C.

W:\50088189\CFX Design Guidelines\CADD and Details\Lighting - Progress Working Files - Maintenance Lighting Details\LT\_002.dgn  
 3/7/2025 3:04:34 PM ggrantham

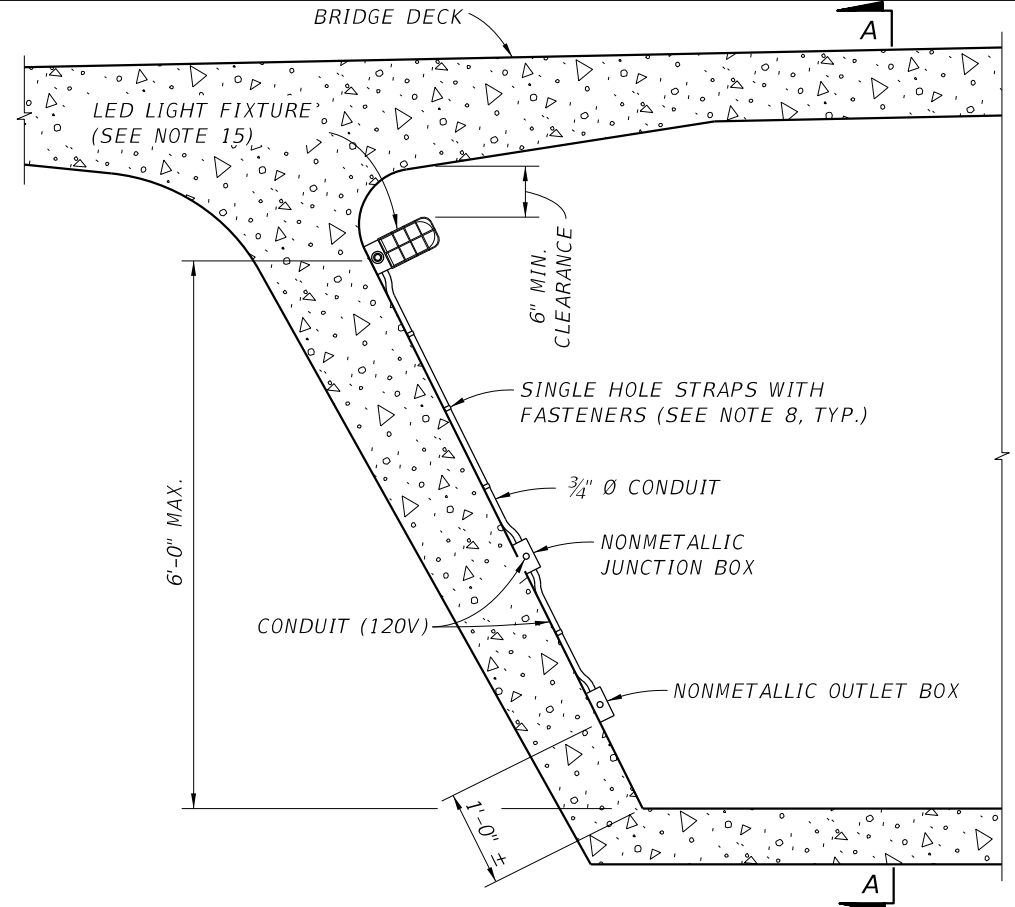

**LIGHTING DETAILS FOR CONCRETE BOX GIRDER BRIDGE**

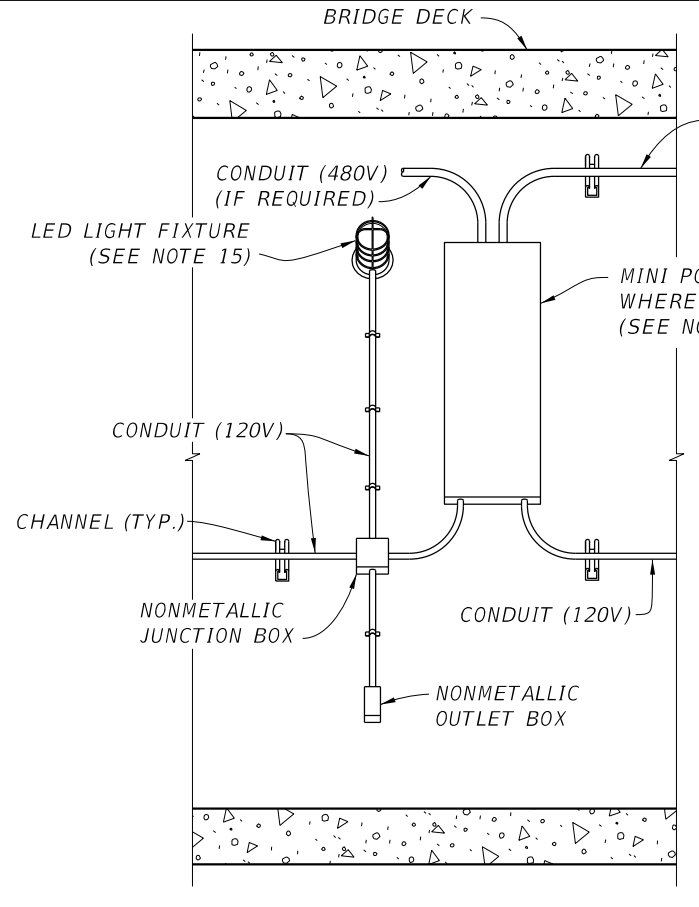

**SECTION A-A**

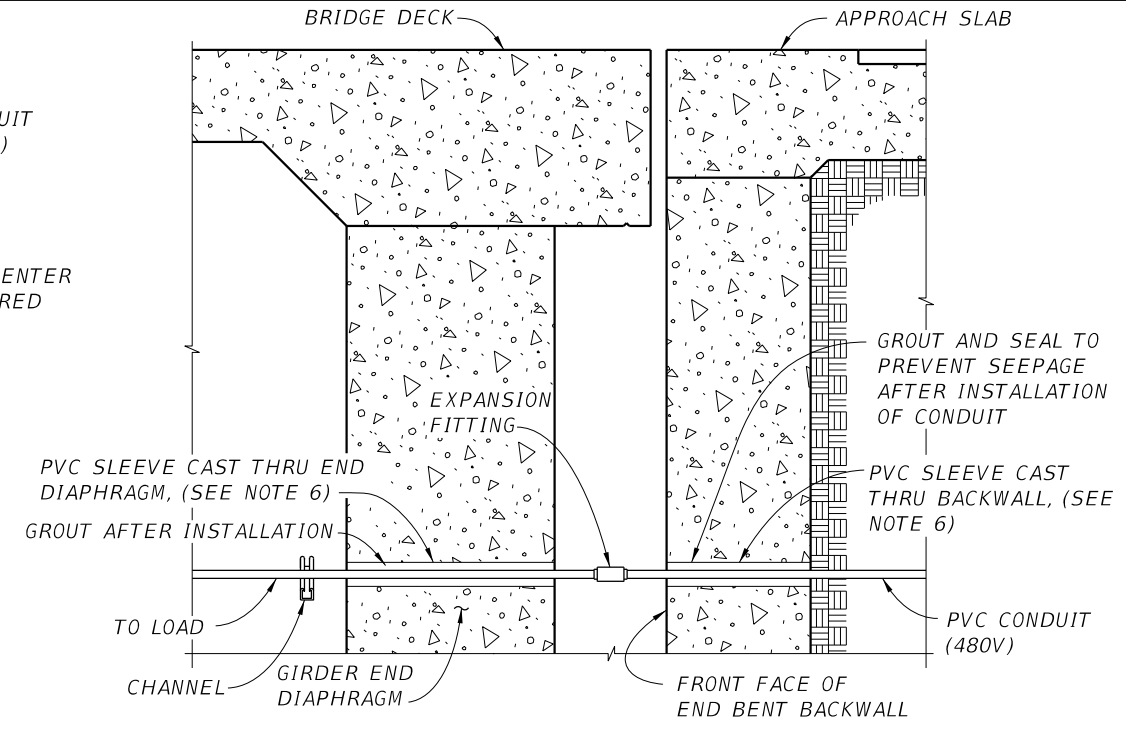

**CONCRETE BOX GIRDER BRIDGE SECTION THRU END BENTS**

CROSS REFERENCE:  
 1. FOR BOX GIRDER MAINTENANCE LIGHTING NOTES SEE SHEET 1.

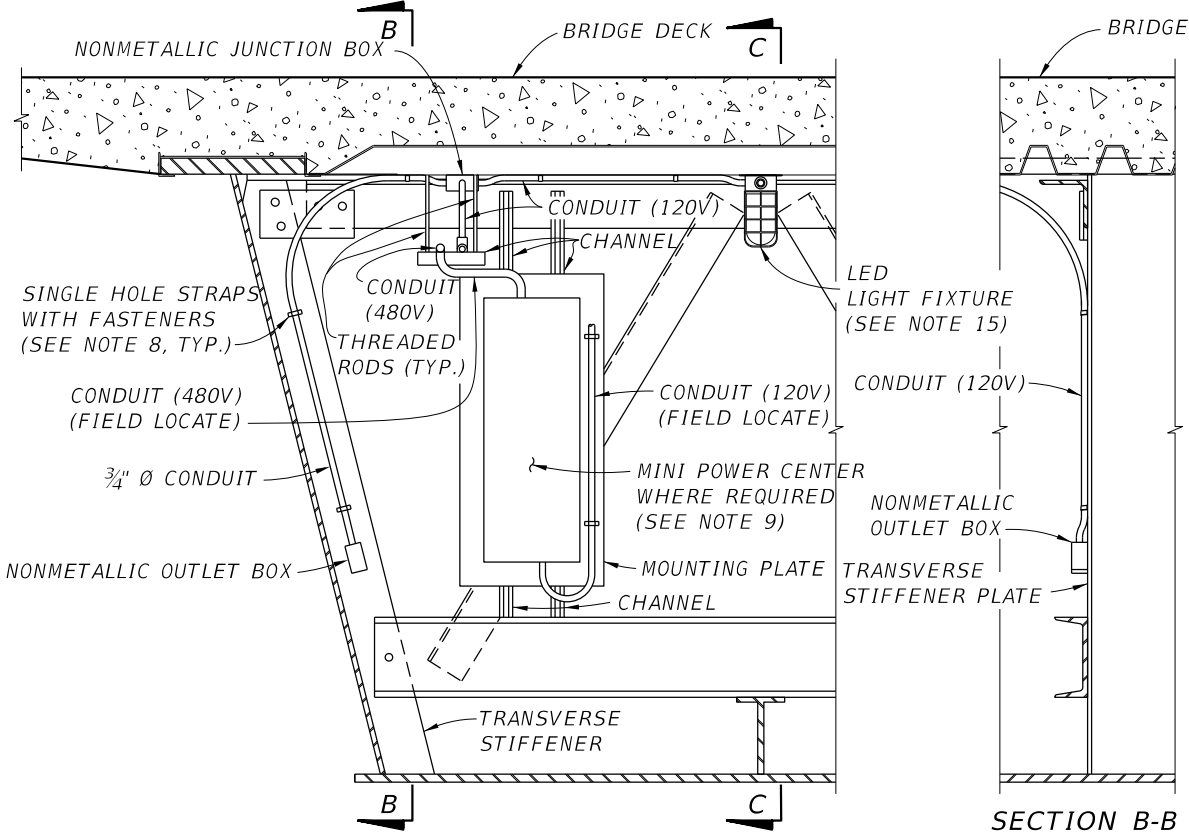

**LIGHTING DETAILS FOR STEEL BOX GIRDER BRIDGE  
 (CROSS FRAME SECTION SHOWN, OTHER TRANSVERSE STIFFENER SECTIONS SIMILAR)**

**SECTION B-B**

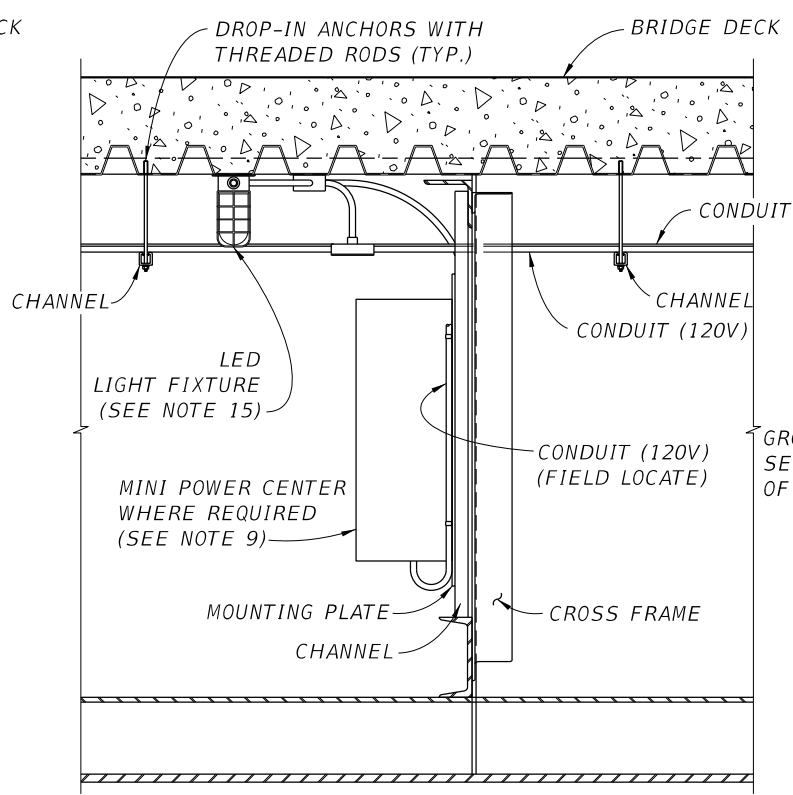

**SECTION C-C**

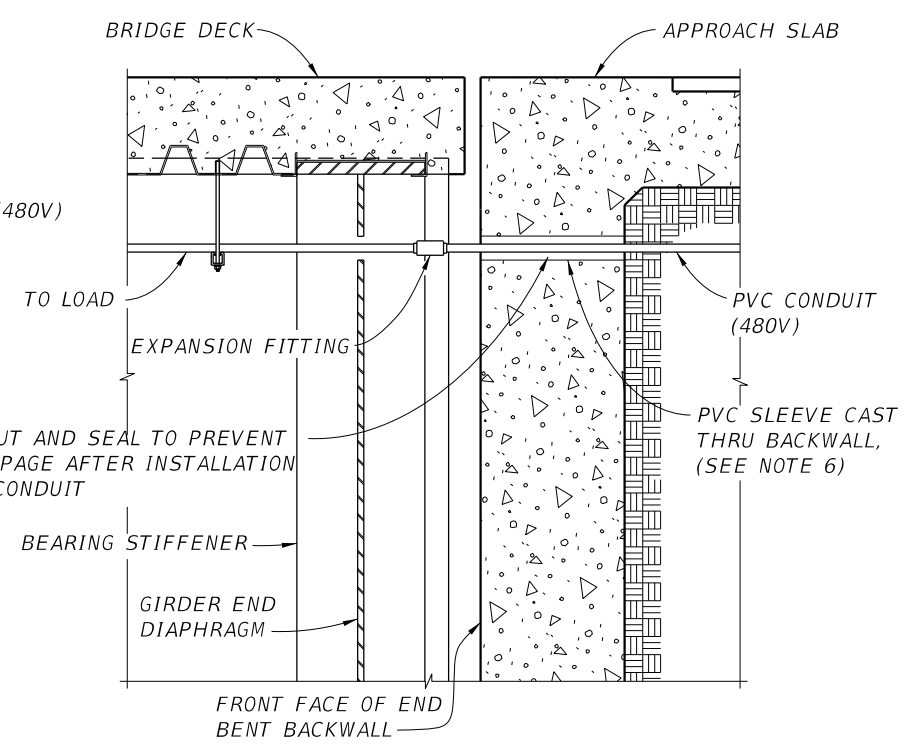

**STEEL BOX GIRDER BRIDGE SECTION THRU END BENTS**

REVISIONS			
DATE	DESCRIPTION	DATE	DESCRIPTION

ENGINEER OF RECORD FULL NAME, P.E.  
 P.E. LICENSE NUMBER 99999  
 ENGINEER OF RECORD COMPANY NAME  
 ENGINEER OF RECORD COMPANY STREET  
 ENGINEER OF RECORD CITY, STATE AND ZIP

PROJECT NAME  
 (1 to 3 LINES)  
 ROAD NO. PROJECT NO.



**MAINTENANCE LIGHTING  
 FOR BOX GIRDERS**

SHEET NO.  
**J-2**

THE OFFICIAL RECORD OF THIS SHEET IS THE ELECTRONIC FILE DIGITALLY SIGNED AND SEALED UNDER RULE 61G15-23.004, F.A.C.

**NOTES:**

1. ALL ENCLOSURES SHALL BE NEMA 4X AT THE POWER SERVICE-ENTRANCE LOCATION. THE SIDES AND TOP OF ALL EQUIPMENT MOUNTED TO THE H-FRAME ASSEMBLY SHALL BE SEALED WITH SILICONE. HOLES SMALLER THAN 1#8" SHALL BE SEALED WITH SILICONE SEALANT INSIDE AND OUT. DO NOT PLACE SILICONE AROUND THE BOTTOM OF THE DEVICE.
2. ENCLOSURES SHALL BE ATTACHED WITH RGS TO THE H-FRAME ASSEMBLY.
3. SPD TYPE 1 SHALL BE INSTALLED ON THE EXTERIOR OF LIGHTING CABINET TO BE CONNECTED ON SUPPLY SIDE OF MAIN CIRCUIT BREAKER INSIDE THE CABINET. THE SPD SHALL HAVE A LED INDICATOR AND BE LIT TO SHOW PROTECTION.
4. ALL SERVICE EQUIPMENT SHALL BE U.L. APPROVED.
5. ALL EDGES TO HAVE 1/2" CHAMFER.
6. DO NOT DRILL OR PUNCH HOLES IN METER BASE. USE PROVIDED KNOCKOUTS.
7. MOUNT KINDORF CHANNEL USING 1/2" BOLT THROUGH POST OR LEAD ANCHOR AND BOLT. KINDORF CHANNEL IS NOT TO EXTEND PAST THE OUTER SIDES OF THE H-FRAME CONCRETE POSTS. DO NOT USE POWER GUN TO SHOOT FASTENERS INTO POST. DO NOT USE PLASTIC ANCHORS.
8. CONCRETE POST SHALL BE IN ACCORDANCE WITH CFX SPECIFICATIONS 639A-3.10.
9. RGS SHALL TRANSITION TO PVC NO LESS THAN 6" BELOW GRADE. A CFX APPROVED RGS TO PVC CONNECTOR MUST BE USED.
10. 6" THICK CONCRETE PAD SHALL BE A MINIMUM OF CLASS I NON-STRUCTURAL 2500 PSI CONCRETE.

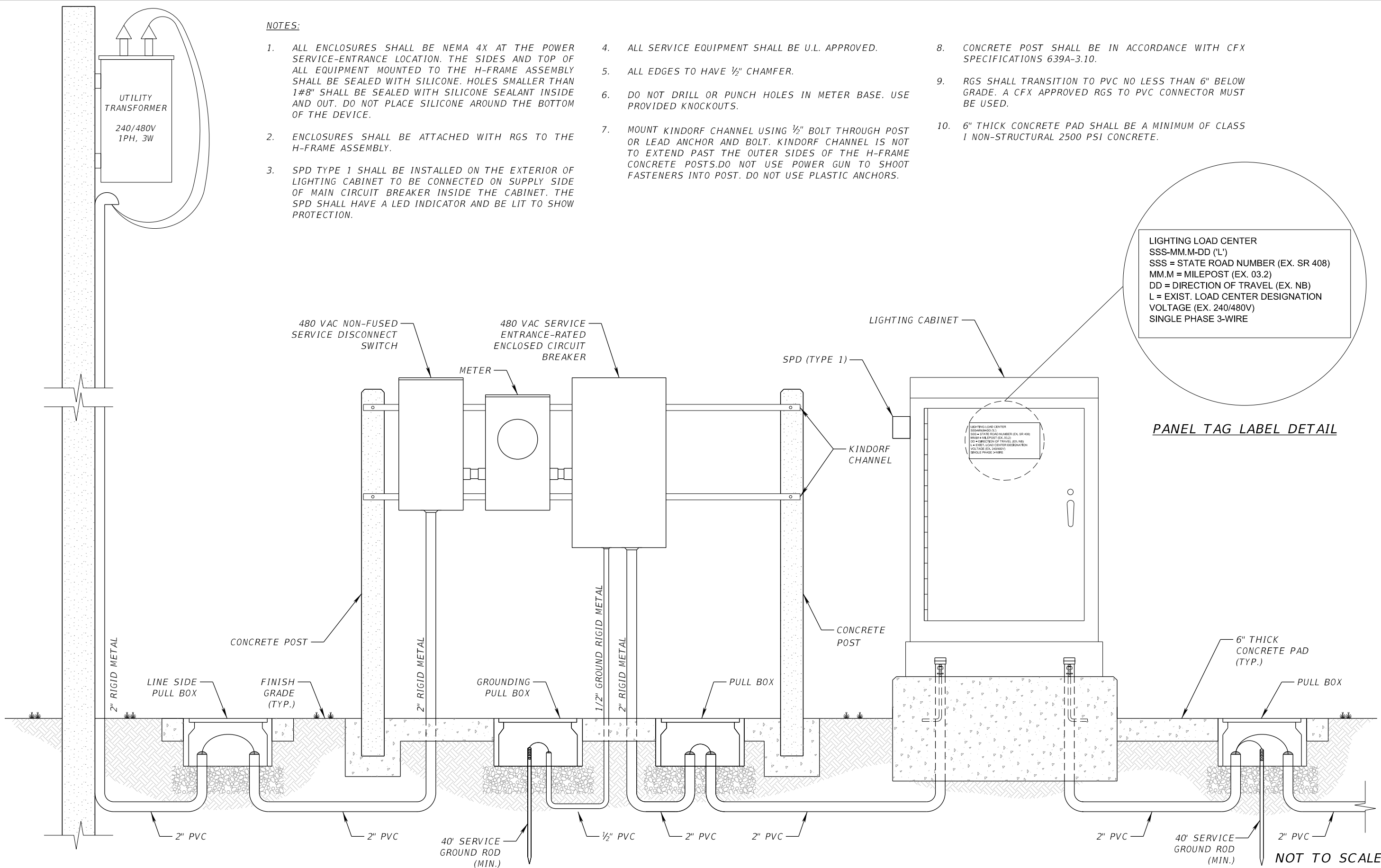

**LIGHTING LOAD CENTER**  
 SSS-MM.M-DD (L)  
 SSS = STATE ROAD NUMBER (EX. SR 408)  
 MM.M = MILEPOST (EX. 03.2)  
 DD = DIRECTION OF TRAVEL (EX. NB)  
 L = EXIST. LOAD CENTER DESIGNATION  
 VOLTAGE (EX. 240/480V)  
 SINGLE PHASE 3-WIRE

**PANEL TAG LABEL DETAIL**

NOT TO SCALE

W:\50088189\CFX Design Guidelines\CADD and Details\Lighting -Progress Working Files\K - Service Point Details\LT\_K01.dgn  
 3:04:34 PM  
 3/7/2025  
 ggrantham

REVISIONS			
DATE	DESCRIPTION	DATE	DESCRIPTION

ENGINEER OF RECORD FULL NAME, P.E.  
 P.E. LICENSE NUMBER 99999  
 ENGINEER OF RECORD COMPANY NAME  
 ENGINEER OF RECORD COMPANY STREET  
 ENGINEER OF RECORD CITY, STATE AND ZIP

PROJECT NAME  
 (1 to 3 LINES)  
 ROAD NO. PROJECT NO.



**ELECTRIC SERVICE ASSEMBLY  
 WITHOUT A TRANSFORMER**

SHEET NO.  
 K-1

THE OFFICIAL RECORD OF THIS SHEET IS THE ELECTRONIC FILE DIGITALLY SIGNED AND SEALED UNDER RULE 61G15-23.004, F.A.C.

W:\50088189\CFX Design Guidelines\CADD and Details\Lighting -Progress Working Files\K - Service Point Details\LT\_K02.dgn  
 3:04:35 PM  
 3/7/2025  
 ggrant@ham

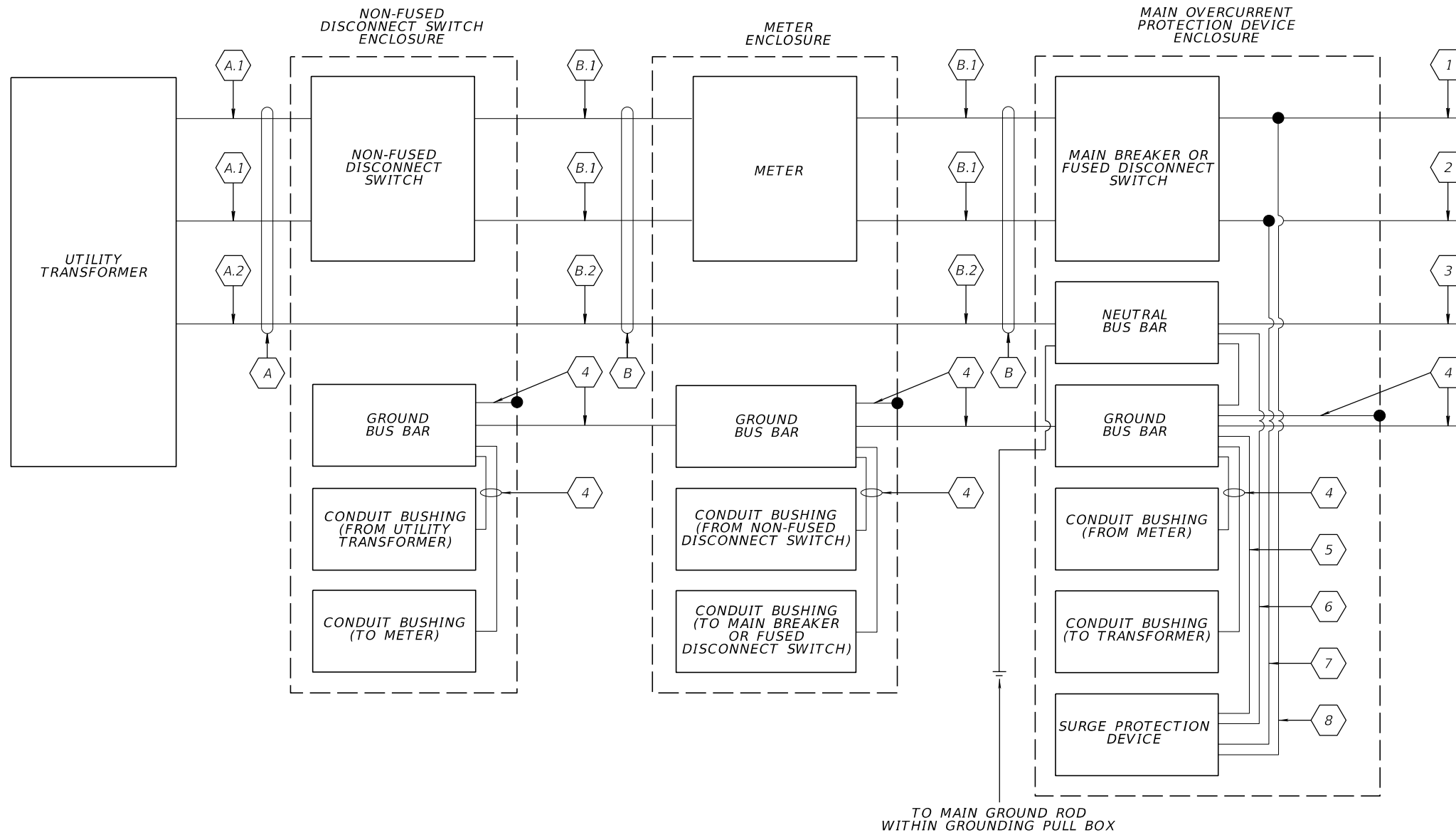

**NOTES TO EOR:**  
 1. CHANGE WIRING AS NEEDED TO MEET PROJECT REQUIREMENTS.  
 2. THIS IS FOR POWER SERVICE 240/480 VAC APPLICATION.

**KEYED NOTES:**

- ① BROWN/YELLOW INSULATED PHASE CONDUCTOR A
- ② BROWN/YELLOW INSULATED PHASE CONDUCTOR B
- ③ WHITE INSULATED GROUNDED NEUTRAL CONDUCTOR
- ④ GREEN INSULATED GROUND CONDUCTOR
- ⑤ SURGE PROTECTION DEVICE GROUND WIRE
- ⑥ SURGE PROTECTION DEVICE NEUTRAL WIRE
- ⑦ SURGE PROTECTION DEVICE LOAD WIRE B
- ⑧ SURGE PROTECTION DEVICE LOAD WIRE A
- Ⓐ OVERHEAD OR UNDERGROUND SERVICE CONDUCTORS
- Ⓐ.1 SERVICE CONDUCTORS
- Ⓐ.2 NEUTRAL CONDUCTOR
- Ⓑ SERVICE ENTRANCE CONDUCTORS
- Ⓑ.1 SERVICE ENTRANCE CONDUCTORS
- Ⓑ.2 NEUTRAL CONDUCTOR

**GENERAL NOTES:**

1. ALL CONDUCTORS ARE TO BE SIZED AS REQUIRED BY THE N.E.C. THE SMALLEST SERVICE CONDUCTOR TO BE USED THROUGHOUT THE SERVICE ASSEMBLY IS #6 AWG COPPER XHHW-2XLP.

REVISIONS				ENGINEER OF RECORD FULL NAME, P.E. P.E. LICENSE NUMBER 99999 ENGINEER OF RECORD COMPANY NAME ENGINEER OF RECORD COMPANY STREET ENGINEER OF RECORD CITY, STATE AND ZIP	PROJECT NAME (1 to 3 LINES)		<b>CENTRAL FLORIDA EXPRESSWAY AUTHORITY</b>	<i>ELECTRICAL SERVICE ASSEMBLY WIRING DIAGRAM WITHOUT A TRANSFORMER</i>		SHEET NO.
DATE	DESCRIPTION	DATE	DESCRIPTION		ROAD NO.	PROJECT NO.				
										K-2

THE OFFICIAL RECORD OF THIS SHEET IS THE ELECTRONIC FILE DIGITALLY SIGNED AND SEALED UNDER RULE 61G15-23.004, F.A.C.



W:\50088189\CFX Design Guidelines\CADD and Details\Lighting - Progress Working Files\K - Service Point Details\LT\_K04.dgn 3:04:36 PM 3/7/2025 ggrant\ham

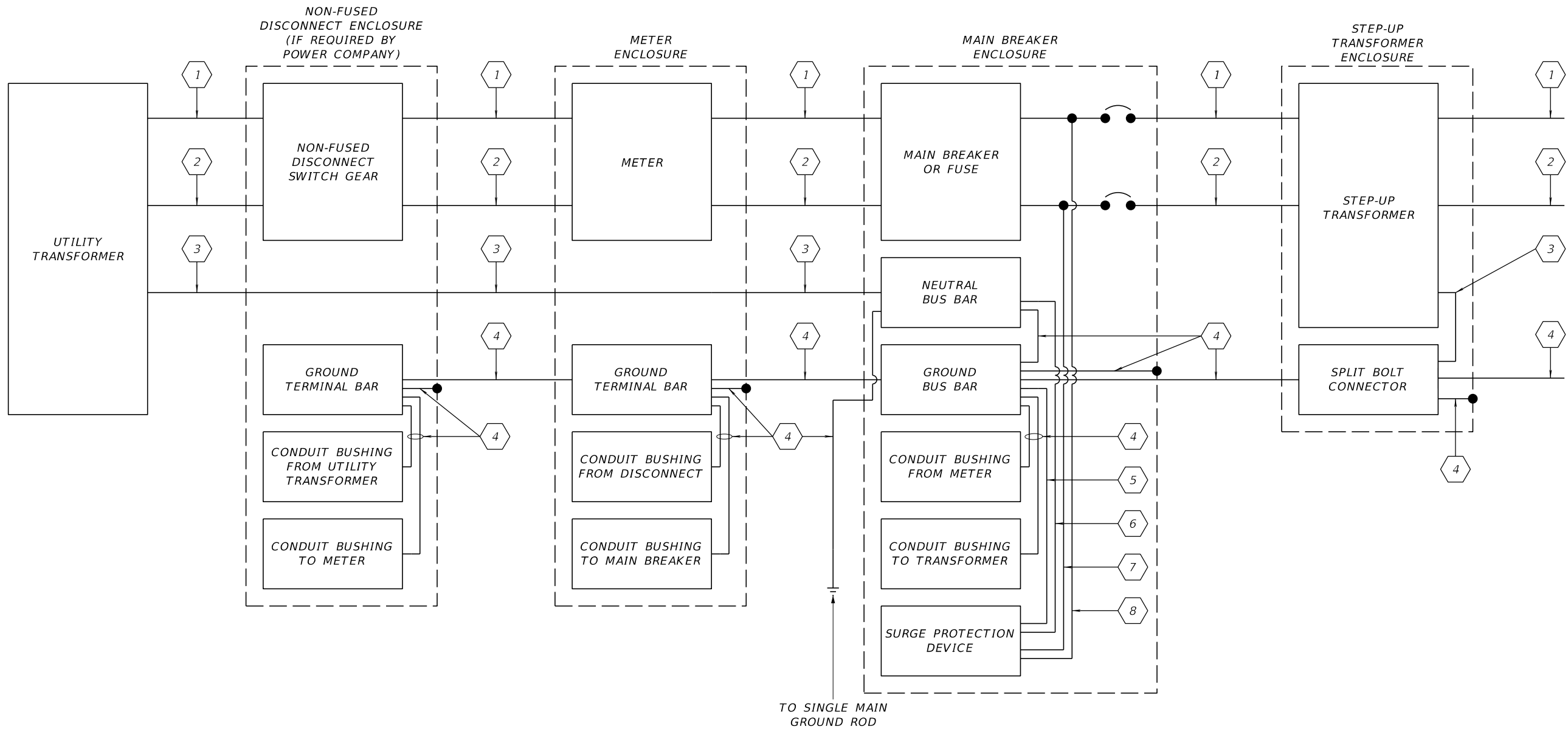

**NOTES TO EOR:**

1. CHANGE WIRING AS NEEDED TO MEET PROJECT REQUIREMENTS.
2. THIS IS FOR POWER SERVICE 120/240 AND OPERATING VOLTAGE 240/480 VAC APPLICATION.

**GENERAL NOTES:**

1. ALL CONDUCTORS ARE TO BE SIZED AS REQUIRED BY THE N.E.C. THE SMALLEST GROUND CONDUCTOR TO BE USED THROUGHOUT THE SERVICE ASSEMBLY IS #6 AWG COPPER XHHW-2XLP.

**KEYED NOTES:**

- 1 BLACK INSULATED LOAD CONDUCTOR A
- 2 RED INSULATED LOAD CONDUCTOR B WHEN PROVIDED/REQUIRED
- 3 WHITE INSULATED NEUTRAL CONDUCTOR
- 4 GREEN INSULATED GROUND CONDUCTOR
- 5 SURGE PROTECTION DEVICE GROUND WIRE
- 6 SURGE PROTECTION DEVICE NEUTRAL WIRE
- 7 SURGE PROTECTION DEVICE LOAD WIRE B
- 8 SURGE PROTECTION DEVICE LOAD WIRE A

REVISIONS				ENGINEER OF RECORD FULL NAME, P.E. P.E. LICENSE NUMBER 99999 ENGINEER OF RECORD COMPANY NAME ENGINEER OF RECORD COMPANY STREET ENGINEER OF RECORD CITY, STATE AND ZIP	PROJECT NAME (1 to 3 LINES)		<b>CENTRAL FLORIDA EXPRESSWAY AUTHORITY</b>	<i>ELECTRICAL SERVICE ASSEMBLY WIRING DIAGRAM WITH A TRANSFORMER</i>		SHEET NO.
DATE	DESCRIPTION	DATE	DESCRIPTION		ROAD NO.	PROJECT NO.				
										K-4

THE OFFICIAL RECORD OF THIS SHEET IS THE ELECTRONIC FILE DIGITALLY SIGNED AND SEALED UNDER RULE 61G15-23.004, F.A.C.

3/7/2025 3:04:36 PM W:\50088189\CFX Design Guidelines\CADD and Details\Lighting\Lighting - Progress Working Files\K - Service Point Details\LT\_K05.dgn gprantham

**GENERAL NOTES:**

1. SEE LIGHTING PLAN SHEETS FOR APPROXIMATE LOCATION OF THE POINT OF CONNECTION. COORDINATE WITH THE LOCAL POWER COMPANY FOR THE SERVICE SOURCE AND POINT OF CONNECTION, EXACT LOCATIONS AND THE NECESSARY REQUIREMENTS FOR A COMPLETE AND OPERATIONAL INSTALLATION.
2. LIGHTING ENCLOSURE SHALL BE FACTORY ASSEMBLED AND TESTED PRIOR TO SHIPMENT TO THE PROJECT SITE FOR INSTALLATION. ALL COMPONENT DEVICES SHALL BE UL LISTED AND LABELED.
3. THE ELECTRICAL COMPONENTS LAYOUT SHOWN IN ONE-LINE DIAGRAM AND SCHEMATIC DETAILS ARE DIAGRAMMATIC. CONTRACTOR SHALL BE FULLY RESPONSIBLE TO INSTALL THE ENTIRE SYSTEM IN ACCORDANCE WITH THE LATEST REQUIREMENTS OF THE NEC, LOCAL POWER COMPANY AND DESIGN REQUIREMENTS.
4. ALL EMPTY CONDUITS SHALL BE CAPPED AND FURNISHED WITH A PULL STRING FOR FUTURE USE.
5. PULL BOX, CONDUCTOR, AND CONDUIT QUANTITIES AND SIZES VARY. REFER TO LIGHTING PLAN SHEETS FOR ADDITIONAL INFORMATION.

**KEYED NOTES:**

- 1 240/480V, SINGLE PHASE, 3-WIRE ELECTRIC UNDERGROUND OR OVERHEAD SERVICE DISTRIBUTION TRANSFORMER.
- 2 JUNCTION BOX AT THE BASE OF THE LOCAL POWER COMPANY'S POLE. COORDINATE REQUIREMENTS WITH THE POWER COMPANY'S REPRESENTATIVE. JUNCTION BOX COVER SHALL BE MARKED "ELECTRIC". SERVICE CONDUCTORS IN 2" RIGID CONDUIT BY THE POWER COMPANY.
- 3 SERVICE CONDUCTORS AND CONDUITS USING PVC FOR UNDERGROUND AND RGS FOR THE ABOVE GROUND INSTALLATIONS.
- 4 SERVICE-ENTRANCE CONDUCTORS IN RIGID GALVANIZED STEEL CONDUIT FOR ABOVE GRADE AND PVC SCHEDULE 40 FOR UNDERGROUND INSTALLATIONS.
- 5 NON-FUSED DISCONNECT SWITCH, NEMA 4X, STAINLESS STEEL.
- 6 METER SOCKET AND GROUNDING BY CONTRACTOR PER POWER COMPANY'S REQUIREMENTS. METER BY POWER COMPANY.
- 7 SERVICE ENTRANCE-RATED ENCLOSED CIRCUIT BREAKER, 600V RATING, 35K AIC, SOLID NEUTRAL, NEMA 4X, STAINLESS STEEL, MAIN BONDING JUMPER, EQUIPMENT GROUNDING BUS BONDED TO ENCLOSURE.
- 8 SURGE PROTECTION DEVICE (SPD), TYPE 1, MOUNTED ON THE SUPPLY SIDE OF SERVICE ENTRANCE RATED ENCLOSED CIRCUIT BREAKER. SPD UNIT SHALL BE UL 1449 LATEST EDITION, 20KA I-NOMINAL, L-N, L-G, AND L-L MODES OF PROTECTION. SURGE CURRENT RATING OF 100KA, SHORT CIRCUIT CURRENT RATING (SCCR) OF 100KA OR GREATER, VOLTAGE PROTECTION RATING (VPR) OF 1000V, FOR OPERATING VOLTAGE OF 240/480V INCLUDING GROUND AND NEUTRAL, USING ASCO MODEL NUMBER 420277SP10AWSJ10. SPD IS TO BE EQUIPPED WITH A PROTECTION STATUS LED.
- 9 PHASE, GROUNDED SERVICE (NEUTRAL), AND EQUIPMENT GROUND CONDUCTORS USING PVC CONDUIT FOR UNDERGROUND AND RGS FOR ABOVE GROUND INSTALLATIONS.
- 10 MAIN CIRCUIT BREAKER, 600V RATING, SOLID NEUTRAL, NEMA 1 ENCLOSURE.
- 11 ELECTRICALLY HELD LIGHTING CONTACTOR USED FOR 2-POLE APPLICATION.
- 12 LIGHTING CONTROL PANEL ENCLOSURE (NEMA 4X, ALUMINUM). ENCLOSURE SHALL BE SINGLE CONTINUOUS HINGED DOOR WITH BACK PANEL, 3-POINT, T-HANDLE LATCHING MECHANISM WITH PLASTIC OR RUBBER ROLLER GUIDES, AND PAD LOCK HASP. DIMENSIONS SHALL BE AS REQUIRED TO ACCOMMODATE THE COMPONENT DEVICES AND MATERIAL SPECIFIED TO BE INSTALLED INSIDE THE ENCLOSURE. GROUND MOUNTED ENCLOSURE PER STANDARD 639-002.
- 13 PANELBOARD WITH COPPER BUSSING. ALL MAIN AND BRANCH BREAKERS, BUSSING AND FEED THROUGH LUGS SHALL BE FULLY RATED. PANELBOARD SHALL BE UL67, NEUTRAL BUS, GROUND BUS, AND NEMA 1 SURFACE MOUNT ENCLOSURE. REFER TO PANELBOARD SCHEDULES FOR ADDITIONAL INFORMATION.
- 14 BRANCH CIRCUIT TO ROADWAY LUMINAIRES (TYPICAL).
- 15 FUSED CONTROL POWER TRANSFORMER, KVA RATING AS NEEDED, SINGLE PHASE, 480V PRIMARY, 120V SECONDARY.
- 16 GROUND FAULT CIRCUIT INTERRUPTER (GFCI) TYPE RECEPTACLE, 120V, 20A, NEMA 5-20R INDUSTRIAL GRADE.
- 17 HAND-OFF AUTOMATIC SELECTOR SWITCH (PART OF LIGHTING CONTACTOR, SHOWN OUTSIDE FOR CLARITY).
- 18 PHOTOCELL (PC) CONTROLLER, 120V RATED.
- 19 COPPER GROUNDING CONDUCTOR IN 1/2" RGS CONDUIT WHERE EXPOSED. BOND GROUNDING TO TOP OF GROUND ROADS VIA EXOTHERMIC WELDING PROCESS. USE 5/8" COPPER CLAD GROUND ROADS BY 40' LONG (MIN.) INSTALLED 12" UNDER FINAL GRADE AT LEAST 20' APART AND BONDED TOGETHER WITH TIN PLATED BARE COPPER (MIN. #2 AWG), BY EXOTHERMIC WELDING. SIZE PER DESIGN REQUIREMENTS.

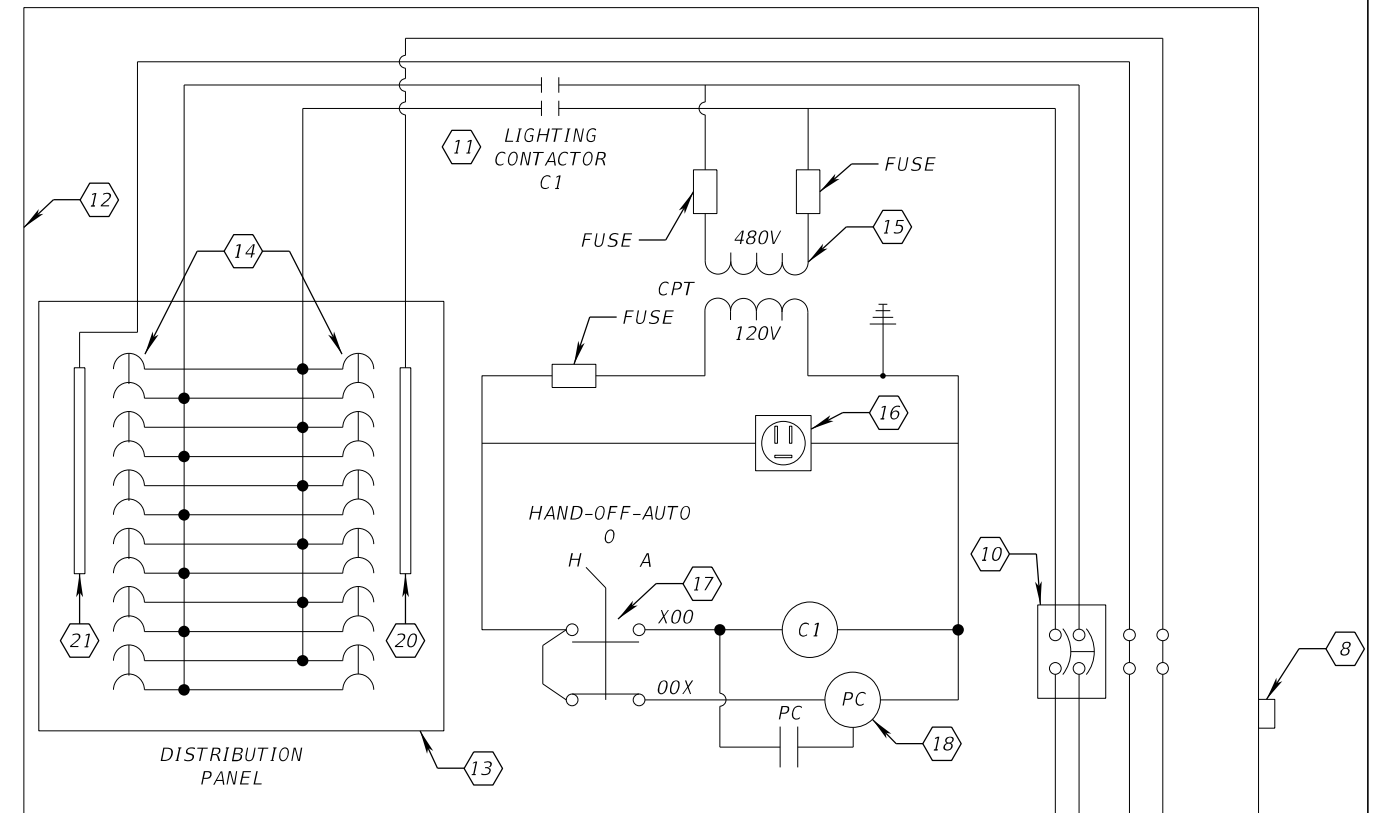

**WIRING DIAGRAM**

- 20 GROUND BUS BAR
- 21 NEUTRAL BUS BAR

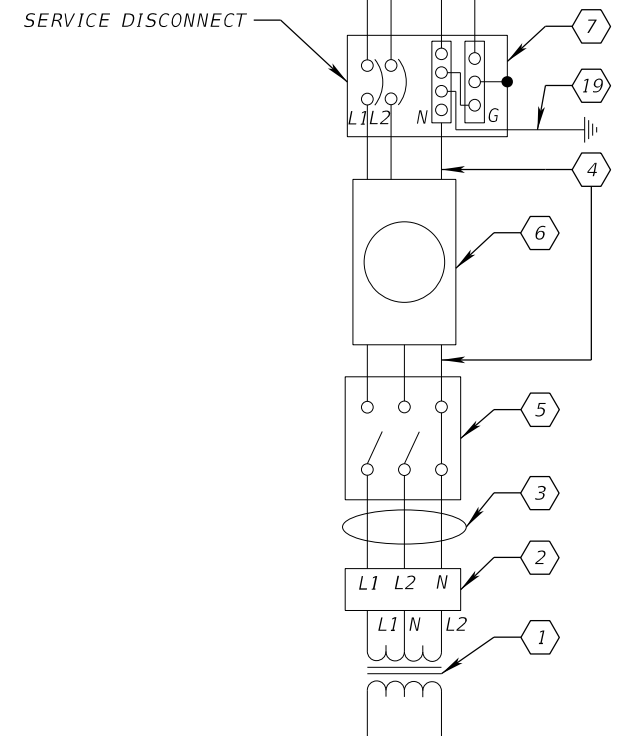

NOT TO SCALE

REVISIONS				ENGINEER OF RECORD FULL NAME, P.E. P.E. LICENSE NUMBER 99999 ENGINEER OF RECORD COMPANY NAME ENGINEER OF RECORD COMPANY STREET ENGINEER OF RECORD CITY, STATE AND ZIP	PROJECT NAME (1 to 3 LINES)		<b>CENTRAL FLORIDA EXPRESSWAY AUTHORITY</b>	<i>SERVICE POINT DETAILS</i>	SHEET NO.
DATE	DESCRIPTION	DATE	DESCRIPTION		ROAD NO.	PROJECT NO.			K-5

THE OFFICIAL RECORD OF THIS SHEET IS THE ELECTRONIC FILE DIGITALLY SIGNED AND SEALED UNDER RULE 61G15-23.004, F.A.C.

W:\50088189\CFX Design Guidelines\CADD and Details\Lighting - Progress Working Files\K - Service Point Details\LT\_K06.dgn  
 3:04:36 PM  
 3/7/2025  
 ggrant@ham

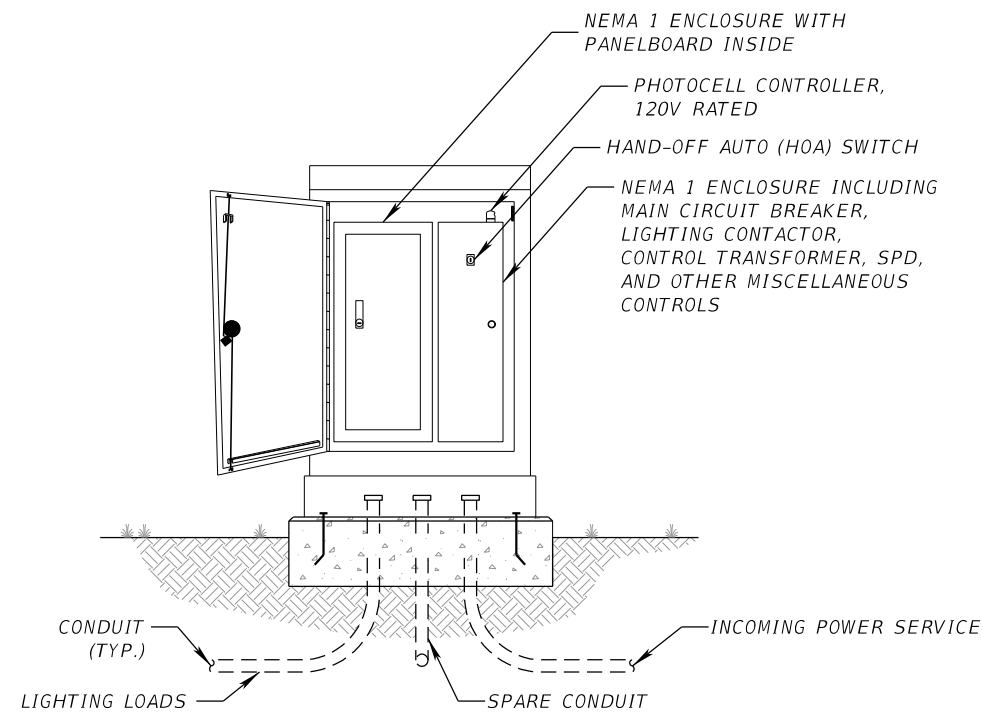

**FRONT VIEW (CABINET INTERIOR)**

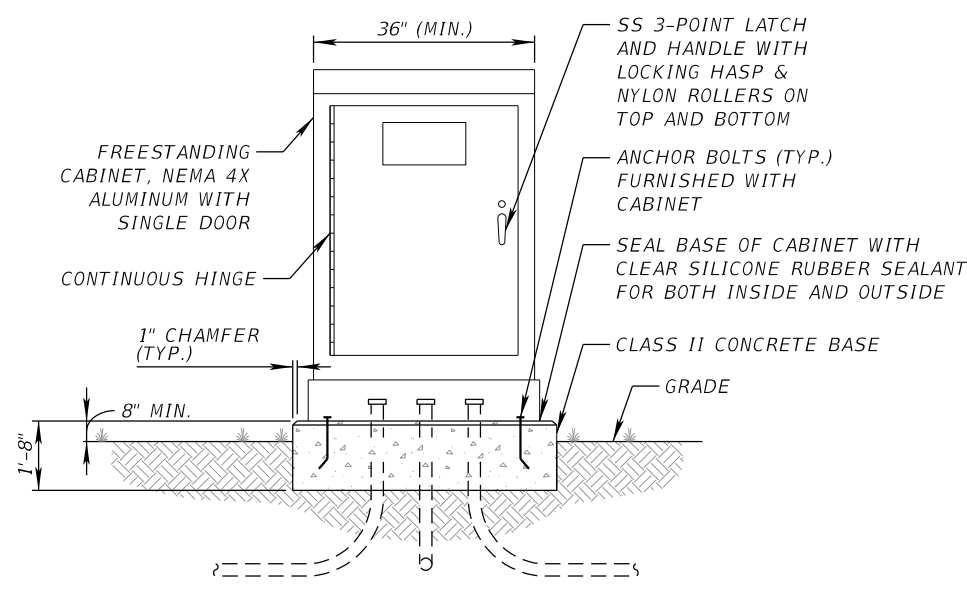

**FRONT VIEW (CABINET EXTERIOR)**

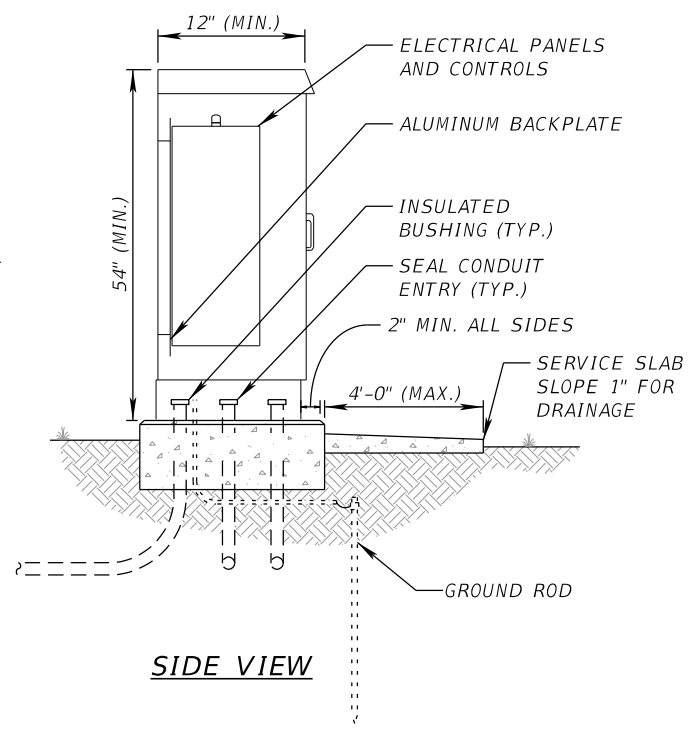

**SIDE VIEW**

**NOTES:**

1. CABINET SHALL BE GROUNDED PER NEC AND CFX STANDARDS AND DETAILED IN THE PLANS.
2. STUB-OUT ONE(1) SPARE 2" PVC CONDUIT BELOW GRADE AND BEYOND CONCRETE BASE. CAP ENDS AND INDICATE LOCATION OF STUB-OUT INSIDE CABINET.
3. CONTRACTOR SHALL FURNISH ENCLOSURE SIZED FOR THE EQUIPMENT.
4. LOAD CENTER/SERVICE POINTS SHALL BE PROVIDED WITH A MINIMUM OF 20% SPARE CAPACITY.

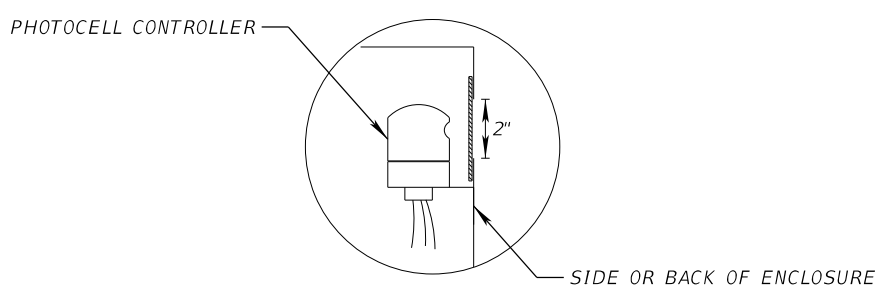

NEMA 4X LISTED WINDOW KIT FOR THE OPERATION AND MOUNTING OF THE PHOTOCELL CONTROLLER

**PHOTOCELL CONTROLLER DETAIL**

NOT TO SCALE

REVISIONS				ENGINEER OF RECORD FULL NAME, P.E. P.E. LICENSE NUMBER 99999 ENGINEER OF RECORD COMPANY NAME ENGINEER OF RECORD COMPANY STREET ENGINEER OF RECORD CITY, STATE AND ZIP	PROJECT NAME (1 to 3 LINES)		CENTRAL FLORIDA EXPRESSWAY AUTHORITY	SHEET NO.  K-6
DATE	DESCRIPTION	DATE	DESCRIPTION		ROAD NO.	PROJECT NO.		
							<b>LIGHTING CABINET DETAILS</b>	

THE OFFICIAL RECORD OF THIS SHEET IS THE ELECTRONIC FILE DIGITALLY SIGNED AND SEALED UNDER RULE 61G15-23.004, F.A.C.



W:\50088189\CFX Design Guidelines\CADD and Details\Lighting - Progress Working Files\K - Service Point Details\LT\_K07.dgn 3:04:36 PM 3/7/2025 ggrant@ham

LIGHTING LOAD ANALYSIS - CFX PROJECT NO. XXX-XXX								
OPERATING VOLTAGE & DELIVERY TYPE	DISTANCE BETWEEN POINT OF SERVICE & LIGHTING CABINET (FT)	LIGHTING CABINET LOCATION	LIGHTING CABINET DESIGNATION	CKT NO.	TOTAL NO. OF FIXTURES	CONNECTED LOAD (AMPS)	CONNECTED LOAD (KVA)	2-POLE BRANCH BREAKER (AMPS)
				A-1				
				A-2				
				A-3				
				A-4				
				SPARE				
				SPARE				
				SPARE				

LIGHTING LOAD ANALYSIS - CFX PROJECT NO. XXX-XXX								
OPERATING VOLTAGE & DELIVERY TYPE	DISTANCE BETWEEN POINT OF SERVICE & LIGHTING CABINET (FT)	LIGHTING CABINET LOCATION	LIGHTING CABINET DESIGNATION	CKT NO.	TOTAL NO. OF FIXTURES	CONNECTED LOAD (AMPS)	CONNECTED LOAD (KVA)	2-POLE BRANCH BREAKER (AMPS)
				B-1				
				B-2				
				B-3				
				B-4				
				SPARE				
				SPARE				
				SPARE				

240/480V, 1PH, __KAIC WITH GROUND BUS												PANELBOARD SCHEDULE "A"				___AMPS, MLO NEMA 1 ENCLOSURE			
POS. NO.	CKT. NO.	AMPS	POLE	BKR	LOAD	POS. NO.	CKT. NO.	AMPS	POLE	BKR	LOAD	POS. NO.	CKT. NO.	AMPS	POLE	BKR	LOAD		
1	1					2	2					3	3						
3						4						5							
5	3					6	4					7	4						
7						8						9							
9						10						11							
11						12						13							
13						14					15								
15						16					17								
17						18					19								
19						20					21								
21						22					23								
23						24													
TOTAL CONNECTED LOAD:		___ KVA																	
TOTAL CONNECTED LOAD:		___ AMPS																	
TOTAL DEMAND LOAD:		___ KVA																	
TOTAL DEMAND LOAD:		___ AMPS																	

240/480V, 1PH, __KAIC WITH GROUND BUS												PANELBOARD SCHEDULE "B"				___AMPS, MLO NEMA 1 ENCLOSURE			
POS. NO.	CKT. NO.	AMPS	POLE	BKR	LOAD	POS. NO.	CKT. NO.	AMPS	POLE	BKR	LOAD	POS. NO.	CKT. NO.	AMPS	POLE	BKR	LOAD		
1	1					2	2					3	3						
3						4						5							
5	3					6	4					7	4						
7						8						9							
9						10						11							
11						12						13							
13						14					15								
15						16					17								
17						18					19								
19						20					21								
21						22					23								
23						24													
TOTAL CONNECTED LOAD:		___ KVA																	
TOTAL CONNECTED LOAD:		___ AMPS																	
TOTAL DEMAND LOAD:		___ KVA																	
TOTAL DEMAND LOAD:		___ AMPS																	

**NOTES:**

- ALL BRANCH CIRCUIT BREAKERS SHALL HAVE A MINIMUM OF 14,000 AMPS FULLY RATED INTERRUPTING CAPACITY.
- PANELBOARDS WITH NEMA 1 ENCLOSURES, UL 67 RATING 5, SHALL BE INSTALLED PAD-MOUNTED, 4X ALUMINUM CABINETS AT THE POWER SERVICE-ENTRANCE LOCATIONS. REFER TO LIGHTING CABINET DETAILS FOR ADDITIONAL INFORMATION.
- THE LEAD LENGTH OF THE SURGE PROTECTION DEVICES (SPD) SHALL BE AS SHORT AND STRAIGHT AS POSSIBLE.
- SURGE PROTECTION DEVICE (SPD), TYPE 2, PRE-WIRED WITH #10 AWG CABLES CONNECTED TO A 30A/2-POLE CIRCUIT BREAKER LOCATED WITHIN LIGHTING CABINET DISTRIBUTION PANEL. SPD UNIT SHALL BE UL 1449 LATEST EDITION, 20KA I-NOMINAL, L-N, N-G, AND L-L MODES OF PROTECTION, SURGE CURRENT RATING OF 50KA, SHORT CIRCUIT CURRENT RATING (SCCR) OF 100KA OR GREATER, VOLTAGE PROTECTION RATING (VPR) OF 1200V, FOR OPERATING VOLTAGE OF 240/480V INCLUDING GROUND AND NEUTRAL, USE ASCO MODEL NUMBER 420277SP05NWSJ10. SPD IS TO BE EQUIPPED WITH A PROTECTION STATUS LED. THE LEAD LENGTH OF THE SURGE PROTECTION DEVICES (SPD) SHALL BE AS SHORT AND STRAIGHT AS POSSIBLE.
- CONTRACTOR SHALL PROVIDE TYPEWRITTEN PANELBOARD CIRCUIT DIRECTORY WITH A CLEAR PLASTIC COVER TO BE PLACED INSIDE OF THE PANELBOARD DOOR. THE CIRCUIT DIRECTORY INFORMATION SHALL MATCH THE POLE IDENTIFICATION TAG INFORMATION OF THE ACTUAL INSTALLED LIGHT POLES.

REVISIONS				ENGINEER OF RECORD FULL NAME, P.E. P.E. LICENSE NUMBER 99999 ENGINEER OF RECORD COMPANY NAME ENGINEER OF RECORD COMPANY STREET ENGINEER OF RECORD CITY, STATE AND ZIP	PROJECT NAME (1 to 3 LINES)		CENTRAL FLORIDA EXPRESSWAY AUTHORITY	PANELBOARD SCHEDULES	SHEET NO.  K-7
DATE	DESCRIPTION	DATE	DESCRIPTION		ROAD NO.	PROJECT NO.			

THE OFFICIAL RECORD OF THIS SHEET IS THE ELECTRONIC FILE DIGITALLY SIGNED AND SEALED UNDER RULE 61G15-23.004, F.A.C.

W:\50088189\CFX Design Guidelines\CADD and Details\Lighting - Progress Working Files\L - Arc Flash & Shock Risk Labeling Details\LT\_L01.dgn 3:04:37 PM 3/7/2025 ggrant@ham

**NOTES:**

1. PLACE ARC FLASH WARNING LABEL ON THE EXTERIOR COVER OF EQUIPMENT AT THE LIGHTING LOAD CENTER LOCATIONS AS SPECIFIED HEREIN.
2. PROVIDE A 4" (H) X 6" (W) SELF-ADHESIVE VINYL LABEL COMPLYING WITH THE ARC FLASH HAZARD LABELING STANDARD DEPICTED ON THIS SHEET.
3. ADJUST ALL PROTECTIVE DEVICE SETTINGS BASED ON THE RESULTS OF THE SELECTIVE COORDINATION AND ARC FLASH HAZARD STUDY PERFORMED FOR THIS PROJECT.
4. PRIOR TO FABRICATION, COORDINATE THE ARC FLASH HAZARD STUDY RESULTS AND DEVICE SETTINGS WITH MANUFACTURERS AND SUPPLIERS OF ELECTRICAL EQUIPMENT TO INCORPORATE THE RECOMMENDATIONS AND NECESSARY MODIFICATIONS.
5. SPECIFIC MODELS OF OVER CURRENT PROTECTION DEVICES WERE USED IN THE ARC FLASH HAZARD STUDY; IF ALTERNATIVE DEVICES ARE USED, THE ARC FLASH HAZARD DATA DEPICTED HEREIN ARE NOT VALID. SUBMIT OVERCURRENT PROTECTION DEVICE SHOP DRAWINGS FOR REVIEW AND APPROVAL BY THE ENGINEER PRIOR TO INSTALLATION; IF THE APPROVED DEVICES VARY FROM THE DEVICES USED IN THE ORIGINAL ARC FLASH HAZARD STUDY, COORDINATE WITH THE ENGINEER TO OBTAIN REVISED ARC FLASH HAZARD DATA FOR EQUIPMENT LABELS AND REVISED OVER CURRENT PROTECTION DEVICE COORDINATION SETTINGS.

<span style="font-size: 2em; font-weight: bold; margin-left: 10px;">WARNING</span>	
<b>ARC FLASH AND SHOCK RISK APPROPRIATE PPE REQUIRED</b>	
<b>FLASH PROTECTION</b>	<b>SHOCK PROTECTION</b>
MIN. ARC RATING (cal/cm <sup>2</sup> ):   SEE TABLE	SHOCK RISK WHEN COVER REMOVED:   SEE TABLE
ARC FLASH BOUNDARY (in):   SEE TABLE	LIMITED APPROACH (in):   SEE TABLE
	RESTRICTED APPROACH (in):   SEE TABLE
DATE OF ANALYSIS:   SEE TABLE	REFERENCE NFPA 70E FOR APPROPRIATE PPE FOR BOTH ARCH FLASH AND SHOCK RISKS.

ARC FLASH AND SHOCK HAZARD DATA						
EQUIPMENT	MIN. ARC RATING (cal/cm <sup>2</sup> )	ARC FLASH BOUNDARY (in.)	SHOCK RISK WHEN COVER REMOVED (OPERATING VOLTAGE)	LIMITED APPROACH (in.)	RESTRICTED APPROACH (in.)	DATE OF ANALYSIS (MONTH/YEAR)
LOAD CENTER A METER DISCONNECT			480 VAC	42	12	
LOAD CENTER A METER			480 VAC	42	12	
LOAD CENTER A MAIN DISCONNECT			480 VAC	42	12	
LOAD CENTER A LIGHTING CABINET			480 VAC	42	12	
LOAD CENTER B METER DISCONNECT			480 VAC	42	12	
LOAD CENTER B METER			480 VAC	42	12	
LOAD CENTER B MAIN DISCONNECT			480 VAC	42	12	
LOAD CENTER B LIGHTING CABINET			480 VAC	42	12	
LOAD CENTER C METER DISCONNECT			480 VAC	42	12	
LOAD CENTER C METER			480 VAC	42	12	
LOAD CENTER C MAIN DISCONNECT			480 VAC	42	12	
LOAD CENTER C LIGHTING CABINET			480 VAC	42	12	
LOAD CENTER D METER DISCONNECT			480 VAC	42	12	
LOAD CENTER D METER			480 VAC	42	12	
LOAD CENTER D MAIN DISCONNECT			480 VAC	42	12	
LOAD CENTER D LIGHTING CABINET			480 VAC	42	12	

REVISIONS				ENGINEER OF RECORD FULL NAME, P.E. P.E. LICENSE NUMBER 99999 ENGINEER OF RECORD COMPANY NAME ENGINEER OF RECORD COMPANY STREET ENGINEER OF RECORD CITY, STATE AND ZIP	PROJECT NAME (1 to 3 LINES)		CENTRAL FLORIDA EXPRESSWAY AUTHORITY	ARC FLASH WARNING LABEL AND NOTES	SHEET NO.
DATE	DESCRIPTION	DATE	DESCRIPTION		ROAD NO.	PROJECT NO.			L-1

THE OFFICIAL RECORD OF THIS SHEET IS THE ELECTRONIC FILE DIGITALLY SIGNED AND SEALED UNDER RULE 61G15-23.004, F.A.C.